

# EN

ORIGINAL INSTRUCTIONS  
OIL HEATER



**Table of contents**

**Notes regarding the instructions** ..... 2

**Safety** ..... 2

**Information about the device** ..... 6

**Transport and storage** ..... 7

**Assembly and start-up** ..... 8

**Operation** ..... 12

**Available accessories** ..... 16

**Errors and faults** ..... 17

**Maintenance** ..... 20







**Technical annex** ..... 23

**Disposal** ..... 27

**Declaration of conformity** ..... 27

**Notes regarding the instructions**

**Symbols**

-  **Danger**  
This symbol indicates dangers to the life and health of persons due to suspended loads.
-  **Warning of electrical voltage**  
This symbol indicates dangers to the life and health of persons due to electrical voltage.
-  **Warning of flammable substances**  
This symbol indicates dangers to the life and health of persons due to flammable substances.
-  **Warning of hot surface**  
This symbol indicates dangers to the life and health of persons due to hot surface.
-  **Warning**  
This signal word indicates a hazard with an average risk level which, if not avoided, can result in serious injury or death.
-  **Caution**  
This signal word indicates a hazard with a low risk level which, if not avoided, can result in minor or moderate injury.

**Note**

This signal word indicates important information (e.g. material damage), but does not indicate hazards.



**Info**

Information marked with this symbol helps you to carry out your tasks quickly and safely.



**Follow the manual**

Information marked with this symbol indicates that the instructions must be observed.

These instructions are only valid with the supplier's instructions for the burner (Ecoflam).

You can download the current version of the instructions via the following link:



IDS 900



<https://hub.trotec.com/?id=42920>

**Safety**

**Read this manual carefully before starting or using the device. Always store the manual in the immediate vicinity of the device or its site of use.**



**Warning**

**Read all safety warnings and all instructions.**

Failure to follow the warnings and instructions may result in electric shock, fire and/or serious injury.

**Save all warnings and instructions for future reference.**

This device must not be used by children and persons under 16 years of age.

Children shall not play with the appliance. Cleaning and user maintenance shall not be made by children under 16 years.



**Warning**

Do not use the device in rooms if persons are present who cannot leave the room independently and who are not under constant supervision.

- Do not use the device in potentially explosive rooms or areas and do not install it there.
- Do not use the device in aggressive atmosphere.
- Only put up the device in an upright, stable position on firm ground.
- Let the device dry out after a wet clean. Do not operate it when wet.

- Do not use the device with wet or damp hands.
- Do not expose the device to directly squirting water.
- Never insert any objects or limbs into the device.
- Do not cover the device during operation.
- Do not remove any safety signs, stickers or labels from the device. Keep all safety signs, stickers and labels in legible condition.
- Attention: In Germany, the Federal Emission Protection Directive applies. Do not operate the device for more than 3 months at the same place. Prior to planning the flue gas system, gather information about the national legislation and contact a responsible specialist.
- Do not sit on the device.
- This appliance is not a toy. Keep away from children and animals. Do not leave the device unattended during operation.
- Check accessories and connection parts for possible damage prior to every use of the device. Do not use any defective devices or device parts.
- Ensure that all electric cables outside of the device are protected from damage (e.g. caused by animals). Never use the device if electric cables or the power connection are damaged!
- The mains connection must correspond to the specifications in the Technical annex.
- Insert the mains plug into a properly fused mains socket.
- Observe the device's power input, cable length and intended use when selecting extensions to the power cable. Completely unroll extension cables. Avoid electrical overload.
- Before carrying out maintenance, care or repair work on the device, remove the mains plug from the mains socket. Hold onto the mains plug while doing so.
- Switch the device off and disconnect the power cable from the mains socket when the device is not in use.
- Do not under any circumstances use the device if you detect damages on the mains plug or power cable. If the power cable is damaged, it must be replaced by the manufacturer, its service agent or similarly qualified persons in order to avoid a hazard. Defective power cables pose a serious health risk!
- When positioning the device, observe the minimum distances from walls and other objects as well as the storage and operating conditions specified in the Technical annex.
- Make sure that the air inlet and outlet are not obstructed.
- Make sure that the suction side is kept free of dirt and loose objects.
- Do not place the device on combustible ground.
- Only transport the device in an upright position.
- Only use original spare parts, for otherwise safe and functional operation cannot be ensured.
- Do not store combustible materials near the device (minimum distance 3 m).
- Take the necessary fire protection measures.
- Only install the device in roofed outdoor areas or in well-ventilated indoor spaces with exhaust system.
- Only position the device near flue pipes or electrical supply control panels that comply with the specified parameters.
- Make sure that the maximum thermal output of the heater is not exceeded (chapter Technical annex).
- Make sure that the air supply is not below the nominal air supply. If the air flow rate is insufficient, the combustion chamber will heat up and the overheating protection thermostat will switch the device on and off continuously (see chapter Errors and faults).
- Do not use the heating device together with a programming device, a timer, a separate remote control system or any other device that automatically switches the heating device on, as there is a risk of fire if the heating device is covered or incorrectly positioned.

### Intended use

The device was developed for the purpose of generating hot air and may only be used in roofed over outdoor areas or in well-ventilated interior spaces whilst adhering to the technical data.

The device is suited for heating large rooms such as tents, warehouses, workshops, construction sites, greenhouses or agricultural halls.

It is intended to be used without frequent site changes.

The device may only be used in rooms with sufficient fresh air supply and exhaust discharge.

The device must only be operated with diesel (10 % biodiesel maximum) and kerosene, but not with petrol, heavy fuel oil, etc.

### Foreseeable misuse

- The device must not be positioned or operated in areas with a high risk of fires or in potentially explosive atmospheres.
- Do not place any objects, e.g. clothing, on the device.
- Do not use the device out of doors, unless under a roof.
- The device must not be operated in rooms with an insufficient combustion air supply.
- Do not make any unauthorised modifications, alterations or structural changes to the device.
- Do not use this device in the vicinity of fuel, solvents, varnishes or other easily inflammable vapours or in rooms where these substances are stored.
- Do not use the device out of doors.

## Personnel qualifications

People who use this device must:

- be aware of the dangers resulting from heat, fire hazard and insufficient ventilation when working with oil heaters.
- be aware of the dangers that occur when handling fuels such as diesel or kerosene
- have read and understood the instructions, especially the Safety chapter.

### Electrically skilled person

Electrically skilled personnel must be able to read and understand electric circuit diagrams, to put electrical systems into service and to maintain them, to wire control cabinets, to ensure the functionality of electrical components and to identify possible hazards from electrical and electronic systems.

### Professionals with the relevant training, e.g. industrial mechanics

Professionals are persons who, on the basis of their professional training, experience and knowledge of the relevant regulations, have sufficient expertise to be able to assess the work assigned to them and to recognise potential hazards. They are allowed to install the device, take it into operation and to perform maintenance activities.

### Instructed person

Instructed persons have been informed of the tasks they were entrusted with as well as of potential hazards resulting from inappropriate behaviour. They are allowed to operate and transport the device and perform simple maintenance activities (cleaning the housing, cleaning the fan).

The device is to be maintained and looked after by instructed personnel.

## Safety signs and labels on the device

### Note

Do not remove any safety signs, stickers or labels from the device. Keep all safety signs, stickers and labels in legible condition.

The following safety signs and labels are attached to the device:

### Safety instructions

The following safety instructions are provided in German and Russian on a label on the device:

- Carefully read the instructions before using the air heater.
- Strictly observe the applicable regulations and local laws regarding installation, maintenance and use of the air heater.
- Do not use the air heater near flammable surfaces or materials.
- Make sure there is sufficient air exchange in the room where the air heater is used.
- Connect the air heater to an earthed socket.
- Only use diesel fuel of type 2 maximum.
- Do not use petrol, waste oil or lubricating oil.
- Do not add fuel while the machine is in operation.
- Do not restart the air heater if excess diesel fuel has accumulated in the combustion chamber.
- Allow the machine to cool down. Do not pull the plug out of the socket while the air heater is in operation. Only stop the air heater with the designated switch on the control panel. The air heater is automatically shut down as soon as it has cooled down sufficiently.
- Regularly clean the filter and, if necessary, remove the water from the container.
- When starting up the device for the first time after it has not been used for a long time, the switch-on procedure may have to be repeated several times. In this case wait about 2 minutes prior to start-up.
- Do not make any changes on the air heater. Contact a qualified customer centre for maintenance interventions.

Disconnect the power supply before carrying out any maintenance work.

The following safety instructions are provided on a label on the device in Italian, German, French, English, Spanish and Russian.

This air heater must be installed in accordance with the applicable regulations and laws and may only be used in sufficiently ventilated rooms. Read the instructions before installing and using the air heater.

The nameplate is provided on the device in German and English:

Type: IDS 900

Article no.: 1430000160

Heating capacity: 236 kW

Air volume flow: 17000 m<sup>3</sup>/h

Mains connection: 1/N/PE ~ 230 V/50 Hz

Fuel consumption: 21.69 l/h

Tank content: -l

Fuel: diesel (10 % biodiesel maximum) or kerosene

### Safety instructions

Noise level: 69 dB(A)  
Weight: 351 kg

The following label is attached to the device in English. The label indicates safety instructions about filling specifications for the tank and the ambient temperature:

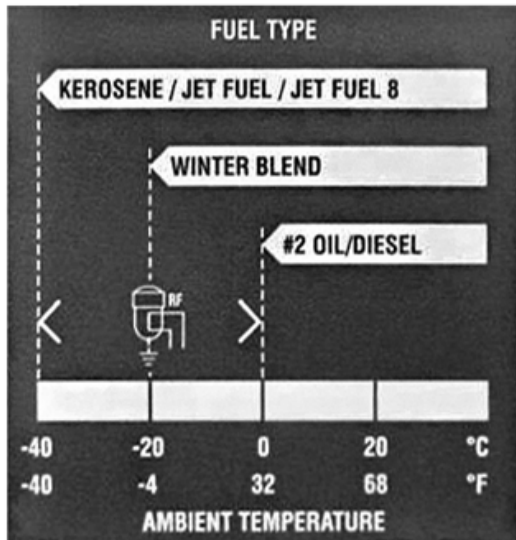

Kerosene fuel can be used at temperatures down to -40°C and at higher temperatures.

Winter fuel mix can be used at temperatures down to -20°C and at higher temperatures.

Diesel fuel can be used at temperatures down to 0°C and at higher temperatures.

The following label on the device indicates the electrical connection.

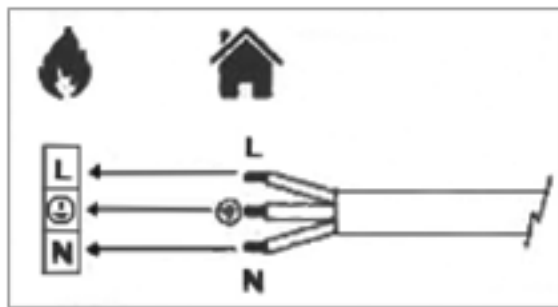

### Residual risks



#### Warning of electrical voltage

Work on the electrical components must only be carried out by an authorised specialist company!



#### Warning of electrical voltage

Before any work on the device, remove the mains plug from the mains socket!  
Do not touch the mains plug with wet or damp hands. Hold onto the mains plug while pulling the power cable out of the mains socket.



#### Warning of flammable substances

Handling fuels entails a risk of fire. Take sufficient precautions when handling fuels such as diesel or kerosene (10 % biodiesel max.)  
Do not spill any diesel or kerosene! Do not inhale the vapours nor swallow any fuel! Avoid skin contact!



#### Warning of hot surface

Parts of the device, especially at the air outlet, become very hot during operation. There is a danger of burning and fire. Do not touch the device during operation!  
During operation observe a safety distance of at least 3 m to the device front! Observe the minimum distance from walls or other objects according to the technical data!



#### Warning of hot surface

Parts of this appliance can become very hot and cause burns. Particular attention is to be paid when there are children or vulnerable persons present!



#### Warning of hot surface

Improper handling entails a risk of burning. Only use the device as intended!



#### Warning

Dangers can occur at the device when it is used by untrained people in an unprofessional or improper way! Observe the personnel qualifications!



#### Warning

The device is not a toy and does not belong in the hands of children.



#### Warning

Risk of death due to suspended loads!  
Make sure that nobody is situated in the immediate proximity.



#### Warning

Risk of suffocation!  
Do not leave the packaging lying around. Children may use it as a dangerous toy.





**Warning**

Improper installation entails a risk of fire.  
Do not place the device on combustible ground.  
Do not place the device on high-pile carpets.



**Warning**

The device must not be covered, there is an imminent fire hazard!

**Behaviour in the event of an emergency**

1. In case of an emergency, immediately extinguish the pilot flame by setting the Heating/ventilation switch to position **0**.
2. In an emergency, disconnect the device from the mains feed-in: Switch the device off and disconnect it from the mains.
3. Remove persons from the danger area.
4. Do not reconnect a defective device to the mains.

**Overheating protection**

The device is provided with a safety thermostat which is activated by overheating of the device (when exceeding the operating temperature).

If the safety thermostat does not switch in the event of overheating, the overheating protection will be tripped. The indicator light of the overheating protection L2 (19) is illuminated in red. In that case the device switches off completely and will not switch on again. If so, please contact the customer service to have the overheating protection replaced.

**Information about the device**

**Device description**

The indirectly fired oil heater serves to heat room air to achieve faster heating of large rooms.

The device is to be operated exclusively with kerosene or diesel fuel (10 % biodiesel maximum) with the following specifications: 10,200 kcal/kg, max. viscosity 1.5°E at 20 °C.

It is an device with indirect combustion to be installed in roofed outdoor areas or in rooms with a sufficient fresh air supply.

The device is equipped with an exhaust gas connection for the discharge of exhaust gases via the chimney.

The oil heater is further equipped with a fuel filter, a fuel pump and a hot air outlet duct. The end piece of the hot air outlet duct can be replaced by ducts with 2 or 4 openings. All openings are to be kept open.

**THIS HEATER IS FOR PROFESSIONAL USE. IT HAS BEEN CAREFULLY DESIGNED FOR MOBILE AND TEMPORARY PROFESSIONAL APPLICATIONS. IT HAS NOT BEEN DESIGNED FOR DOMESTIC USE NOR FOR COMFORT HEATING AND SHOULD NEVER BE USED TO HEAT CLOSED ROOMS WITHOUT ADEQUATE VENTILATION.**

**Functional principle**

The device generates warmth by preparing the sucked-in, cold air at the enlarged area of the combustion chamber, the heat exchanger. The burner of the device sucks in the required combustion air from the outside via air inlet nozzles or from the room to be heated. If the air is sucked in from the room to be heated, the room must be sufficiently ventilated. The air to be heated is completely isolated from the combustion chamber, where the fuel is burned. The combustion products are discharged into the open air through a flue pipe. The sucked-in air is heated and fed back to the environment via the air outlet.

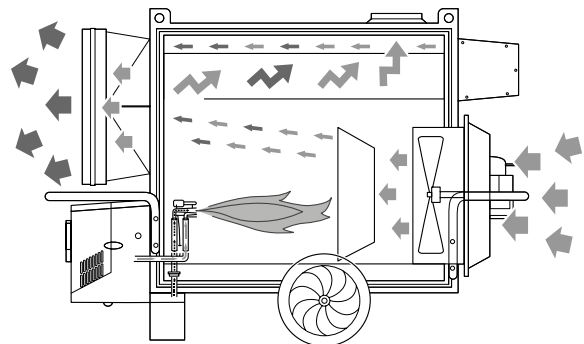

## Device depiction

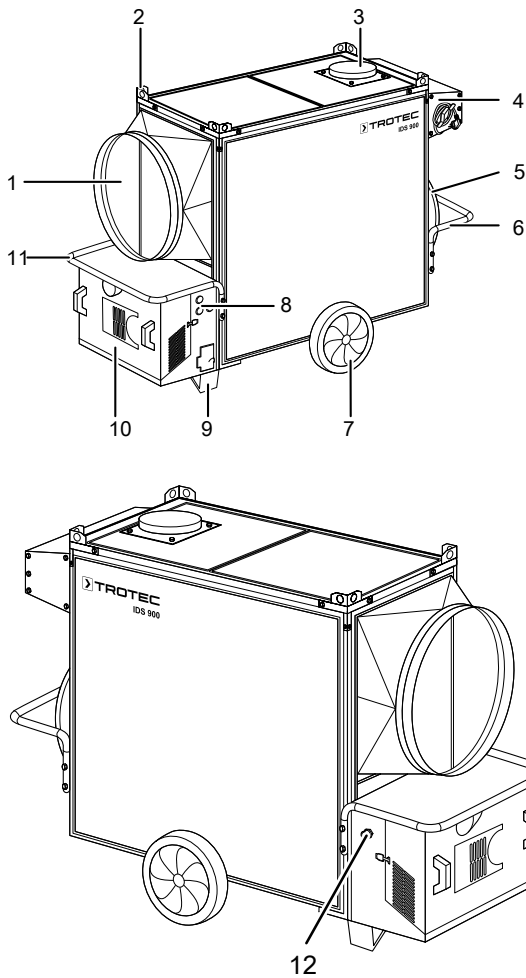

No.	Designation
1	Air outlet
2	Stop bolt
3	Flue pipe connection
4	Control box
5	Cooling fan
6	Protective bar
7	Wheel
8	Thermostat housing
9	Foot
10	Burner housing
11	Transport handle
12	Tank connection with cover

## Transport and storage

### Note

If you store or transport the device improperly, the device may be damaged.  
Note the information regarding transport and storage of the device.

### Transport

To make the device easier to transport, it is fitted with a transport handle and two wheels.

**Before** transporting the device, observe the following:

- Switch the device off.
- Hold onto the mains plug while pulling the power cable out of the mains socket.
- Do not use the power cable to drag the device.
- Hold the front handles when repositioning or transporting the device. The heater will move on its rear wheels.
- Allow the device to cool down sufficiently.

### Storage

**Before** storing the device, proceed as follows:

- Switch off the device.
- Hold onto the mains plug while pulling the power cable out of the mains socket.
- Allow the device to cool down sufficiently.

When the device is not being used, observe the following storage conditions:

- dry and protected from frost and heat
- in an upright position where it is protected from dust and direct sunlight
- with a cover to protect it from invasive dust, if necessary

## Assembly and start-up

### Scope of delivery

- 1 x device
- 1 x manual
- 1 x hose connector, Ø 700 mm
- 1 x connection kit for an external oil tank

### Unpacking the device

1. Open the cardboard box and take the device out.
2. Completely remove the packaging.
3. Fully unwind the power cable. Make sure that the power cable is not damaged and that you do not damage it during unwinding.

### Assembly

Upon delivery the device is partially preassembled. The electric switch panel, burner, fan thermostat, overheating thermostat and safety thermostat with manual restart are already connected.

### Power connection and settings prior to assembly

1. Check the connection to the power supply before commissioning the air heater.
  - ⇒ Make sure that the values of the power supply network correspond to the specifications on the identification plate.
2. Then connect the power cable to a properly secured socket. On construction sites, there must be an RCD upstream of the socket according to VDE 0100/0105.

## Floor installation and ceiling mounting



### Danger

### Suspended loads!

### Risk of death due to falling loads.

The air heater can be mounted as follows:

- on the floor in a stable position
- suspended from the ceiling using ropes and/or chains with a suitable size and length fastened to the four suspension points

The minimum distance to walls, to the floor and / or to the ceiling must be at least 2 m.

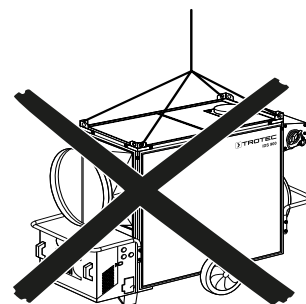
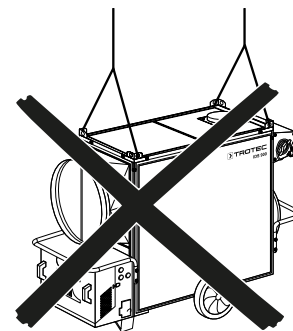
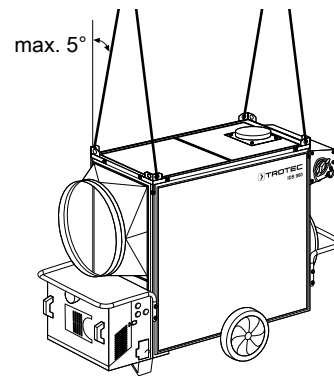



### Connection to the hot air feed ducts

The hot air distributor is designed for operation with direct air distribution.

The hot air opening can be replaced with a 2-way or 4-way distributor head in order to divide the hot air flow by means of flexible channel modification.

1. Disassemble the original outlet nozzle.
2. Replace the original outlet nozzle with the 2-way or 4-way distributor head.

In individual cases, the devices can also be connected to ducts with the corresponding diameter.

Have the following checks and rectifications carried out by a qualified electrician if the fixtures are connected to ducts of the corresponding diameter or if significant changes have been made to the hot air distribution circuit (e.g. changing the length or diameter of the pipes and number or curves):

- The power requirement of the air motor must be checked. It must not exceed the specified value.
- It must be checked whether the air flow rate corresponds to the nominal flow rate.

### Connection to the fuel supply

Always observe the installation, adjustment and operating regulations stipulated by the local and/or national laws regarding the use of air heaters.

The following is to be observed for positioning:

- Before planning the exhaust system, inform the responsible chimney sweep according to DIN 18160.
- Have the device installed by an expert technician.
- Have the exhaust emission of the burner checked at regular intervals.
- Risk of injury due to poisoning.
- Improper installation causes health problems.

In order to connect the device to the fuel oil pipe, the fuel oil tank is to be connected to the fuel pump:

- directly using the fuel oil pump of the burner  
Observe the dimensions and lengths specified in the burner's operating manual.
- indirectly using an auxiliary pump for the fuel oil  
Contact the customer service for a proper dimensioning of the system.

### Connection to the smoke outlet duct

The smoke outlet ducts must be made of steel in accordance with EN 1443.

The combustion efficiency and the proper burner operation depend on the chimney draught. For connection to the chimney pipe, observe the applicable legal regulations and the following provisions:

- The chimney connection must be as short as possible and ascending (minimum height 1 m).
- There must be no sharp curves or reductions in cross-section.
- Always provide a wind shield to prevent the penetration of water or clogging of the smoke outlet due to wind.
- The draught of the chimney sweep must not be lower than the nominal value.
- Every air heater must have its own chimney.



#### Info

The use of concentric pipes for smoke outlet or intake of combustion air is expressly prohibited for this device. It can severely and permanently affect their functioning.

### Position for the flue pipe

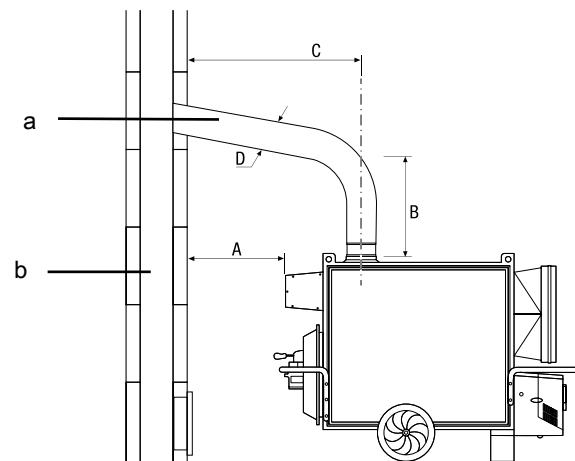

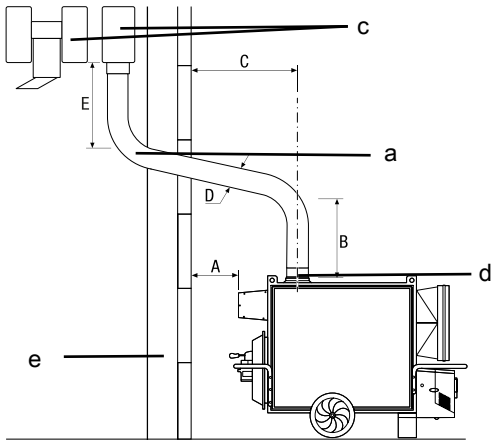

No.	Designation	No.	Designation
A	min. 2 m	a	Wall duct with elbow min. 5°
B	min. 1 m	b	Flue pipe
C	as short as possible	c	Draught booster H-shaped
D	≥ Ø 120 mm/150 mm	d	Flue pipe connection
E	min. 1 m	e	Outer wall

**Positioning**

A number of spatial and technical conditions have to be considered for the selection of the device's installation site. Non-observance may impair the proper functioning of the device or the accessories or can entail risks of personal injury and property damage.

The following is to be observed for positioning:

- The device may only be operated on roofed over surfaces.
- Do not operate the device for more than 3 months at the same place. Prior to planning the flue gas system, gather information about the national legislation and contact a responsible specialist.
- The device is to be set up in a stable position on incombustible ground.
- The device must be set up in close proximity to a chimney, an outer wall or on an open, ventilated surface.
- The device must be connected to a properly secured mains power socket.
- The room where the device is positioned must be sufficiently ventilated.  
Ensure a sufficient fresh air supply, especially when there are people or animals in the same room with the device!
- The minimum distance between the wall and the air inlet opening of the device must be at least 2 m (see figure).
- The minimum distance between the device and combustible materials must be at least 3 m.
- The inlet and outlet openings must not be covered.
- There must be no walls or large objects near the device.
- There must be a sufficient number of fire extinguishers available.

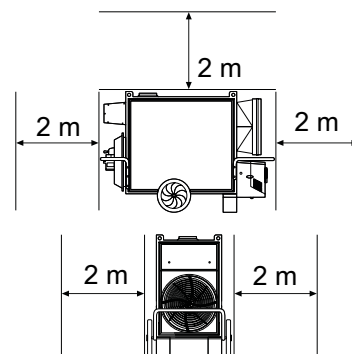

## Start-up

The following is to be observed prior to commissioning:

- Check the scope of delivery of your device for completeness. If the scope of delivery is incomplete, please contact the Trotec customer service or the specialist dealer where you purchased the device.
- Check the device and its connection parts for potential damage.
- Observe the conditions described in the chapter Positioning.
- Connect the external tank (see Establishing the oil supply).
- Check the device for its proper condition prior to start-up and at regular intervals during application.
- Check whether the characteristics of the power grid conform to those on the nameplate.
- Each time before you plug the mains plug into the mains socket and switch on the device, make sure that the fan is moving freely.
- Connect the power cable to a properly secured socket. On construction sites, there must be a residual current device (RCD) upstream of the socket in accordance with national regulations (in Germany: VDE 0100/0105).
- When starting up the device after it has not been used for a long time, the switch-on procedure may have to be repeated several times. In this case wait about 2 minutes prior to start-up.
- The initial start-up must be carried out by a qualified electrician who verifies whether the combustion parameters are correct.

## Inserting the probe

### Note

The initial start-up must be carried out by a qualified electrician who verifies whether the combustion parameters are correct.

### Note

The burner is preset at the factory. This setting may deviate from the required setting. It must therefore be checked and, if necessary, corrected during start-up.

The settings (fuel oil pressure of the burner, combustion head position, air regulation) can be found in the "Technical Data" table.

Insert the probe used for regular checks of the combustion and exhaust gas temperature as follows:

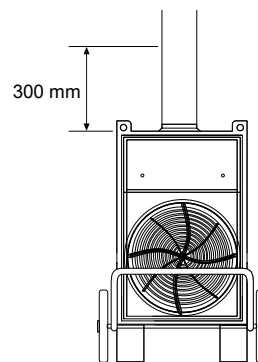

The combustion is stable and clean if the combustion parameters have the following values:

Bacharach index: 0 (white)

CO<sub>2</sub>: 11 / 12.5 %

Oxygen (O<sub>2</sub>): 4.5 / 6 %

CO<sub>max</sub>: 500 ppm

- Depending on the fuel used and on the installation conditions (height level, combustion air intake with or without air inlet etc.), readjustment of the burner may be required if the combustion parameters are incorrect.
- After completion of the acceptance inspections, seal the hole for inserting the probe with a material that is heat-resistant and guarantees tightness of the duct.

**Establishing the oil supply**

Quick couplings are used to connect the device to an external tank.

- ✓ Switch the device off according to the Shutdown chapter.
  - ✓ Before attempting to connect the external tank, wait until the device has cooled down completely.
  - ✓ Only use fuel suitable for the device (see technical data).
1. Position the device on firm, level and incombustible ground.
  2. Remove the cover from the tank connection of the external tank.
  3. Remove the cover of the device from the tank connection.
  4. Attach the feed and return hose to the tank connection of the external tank using the quick couplings.
  5. Attach the feed and return hose to the tank connection of the device using the quick couplings.
  6. Make sure that the hose is firmly attached to avoid leakage.
  7. The device is now connected to the oil supply.

**Note**

If the tank is empty, the burner flame extinguishes and the device switches off automatically.

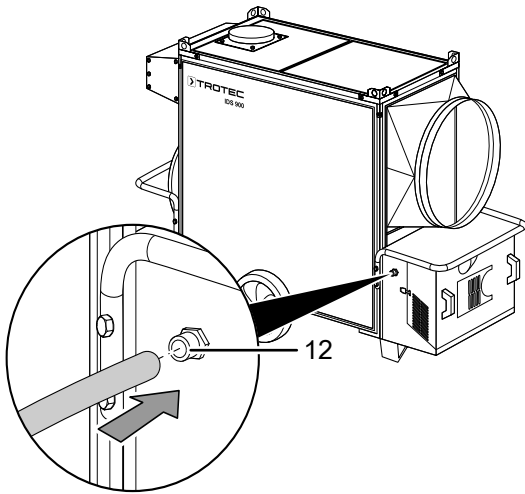

**Operation**

The device may only be used by accordingly instructed persons.

**Operating elements**

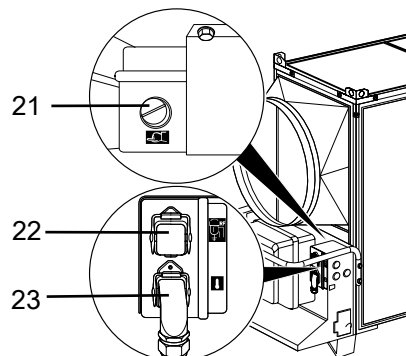
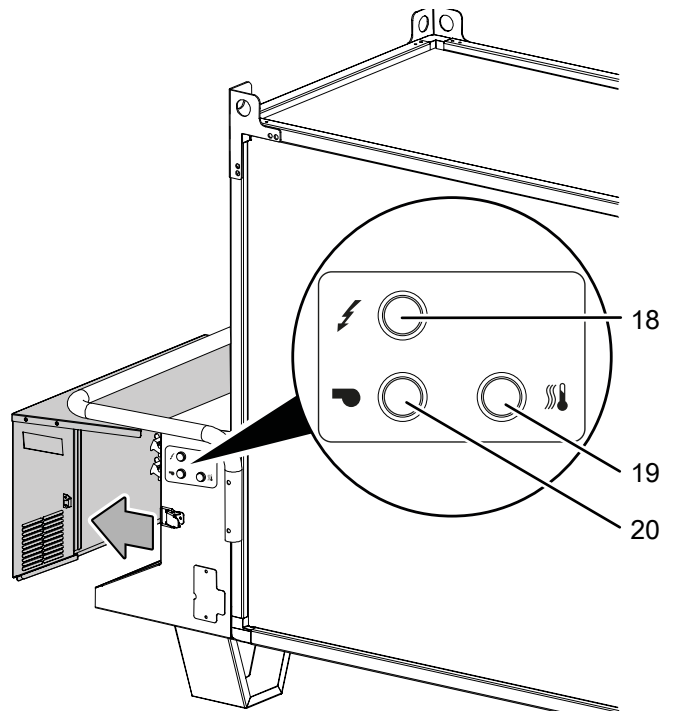
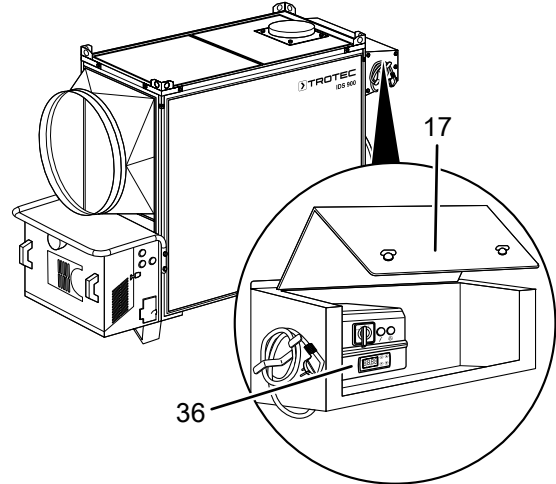

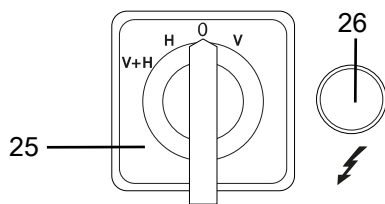
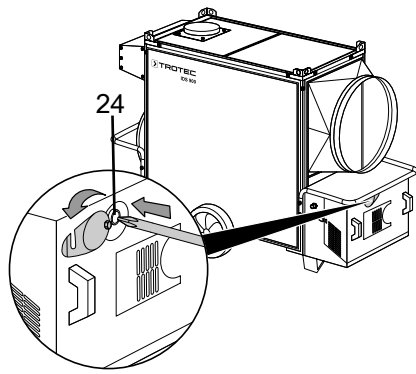

No.	Designation
17	Electrical control box cover
18	Indicator light for thermostat's power supply
19	Safety thermostat indicator light (overheating)
20	Burner indicator light
21	manual reset of the safety thermostat (reset button)
22	Room thermostat socket
23	Connection for oil preheating
24	Burner reset button with lamp
25	Heating/ventilation switch (on/off switch)
26	Operating control lamp
36	Temperature controller with LCD

## Control panel

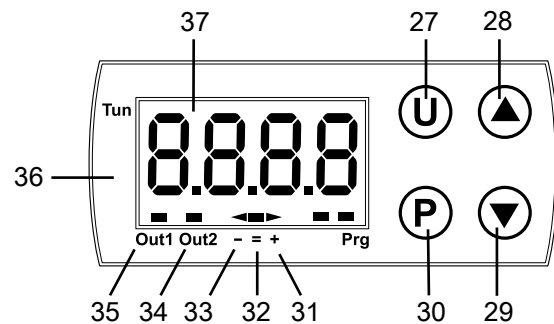

No.	Designation	Meaning
27	<b>U</b> button	Confirms a setting.
28	<b>▲</b> button	If you press the <b>▲</b> button twice, the operating time in hours (h) will be displayed. The indicated time is not the effective heating time but the time during which the device has been supplied with current and switched on. If you press the button once, you can navigate to the previous value.
29	<b>▼</b> button	Navigates to the following value.
30	<b>P</b> button	Press and hold, then the editing mode is displayed. Press briefly to confirm an entry.
31	<b>+</b> symbol	If the red arrow above the <b>+</b> symbol lights up, the temperature is above the set value.
32	<b>=</b> symbol	If the green LED above the <b>=</b> symbol lights up, the temperature corresponds to the set nominal value.
33	<b>-</b> symbol	If the red arrow above the <b>-</b> symbol lights up, the temperature is below the set value.
34	<b>Out 2</b> LED	Indicates the operating condition of the burner thermostat.
35	<b>Out 1</b> LED	Is illuminated when the fan is switched on.
36	Temperature controller with LCD	Records the outlet temperature and the operating hours. Control of the trigger temperature of the burner thermostat and fan thermostat.
37	Display	Indicates the measured temperature in °C.

**Switching the device on**

The device has the following operating modes:

- In operating mode **0**, the burner is switched off.
- In operating mode **V**, only the fan operates.
- In operating mode **V+H**, the fan operates continuously and the burner runs until the predefined room temperature is reached.
- In operating mode **H**, the burner is switched on. The fan, on the other hand, only operates when the combustion chamber is sufficiently heated. When the predefined room temperature is reached, the burner switches off. The fan only continues to run until the combustion chamber has cooled down completely.

In general, the device continues to operate until the desired room temperature is reached.

1. Lift the panel (17) of the control box.
2. Make sure that the Heating/ventilation switch (25) is set to operating mode **0**.

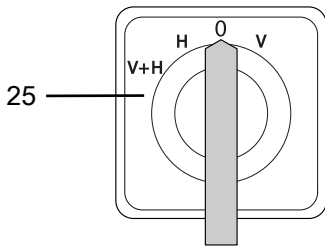

3. Turn the air heater to operating mode **V** using the Heating/ventilation switch (25).

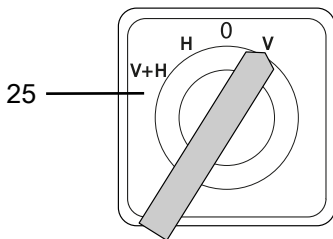

⇒ The green power operating control lamp (26) lights up.

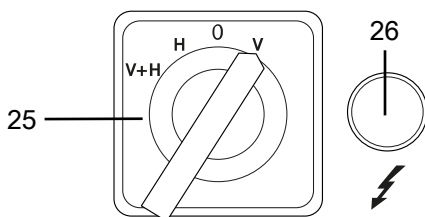

⇒ The fan (5) is switched on.

4. Then turn the switch (25) to operating mode **H** or **V+H**.

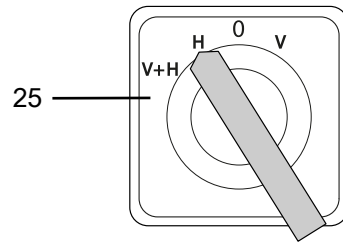

⇒ The burner starts the start-up and pre-purging cycle and the flame is ignited. After the combustion chamber has been preheated for several minutes, the main fan switches on.

Observe the following:

- In case of a failure of the air during start-up or operation, please refer to the "Errors and faults" chapter to find the cause for the malfunction.
- After a safety shutdown of the burner, the lamp of the burner reset button (24) lights up. Press the burner reset button (24) for three seconds to restart the air heater.

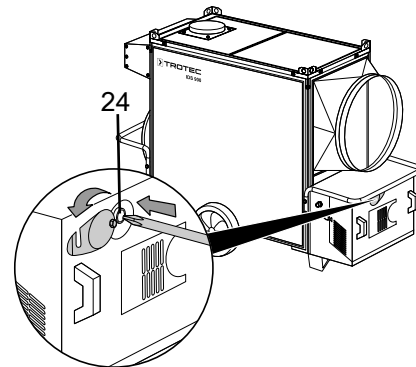

- After a safety shutdown of the thermostats, the safety thermostat indicator light (overheating) (19) lights up. The indicator light (19) is located on the side of the burner housing.

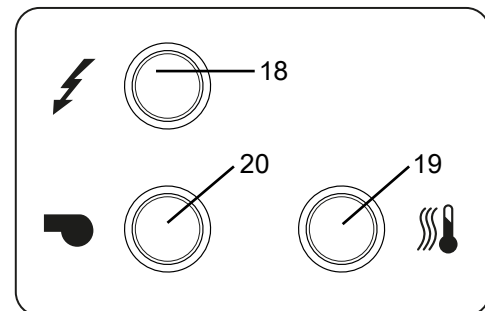

- Press the manual reset of the safety thermostat (21) to restart the air heater.



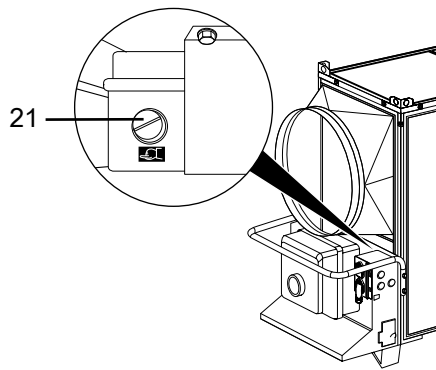

### Control of the trigger temperature of the fan thermostat

The temperature controller is programmed in a way that it automatically switches the main fan on or off depending on the temperature set for the combustion chamber. This prevents cold air from being blown out when the burner starts and the combustion chamber is not yet sufficiently heated.

This ensures that the internal residual heat is discharged upon switch-off.

The default temperature setting is 35 °C with a hysteresis of 5 °C.

### Operating condition of the fan thermostat

- LED "OUT 1" (35) is illuminated in red: the fan is switched on.
- LED "OUT 1" (35) is not illuminated: the fan is switched off.

### Control of the trigger temperature of the burner thermostat

The temperature controller is programmed in a way that it automatically switches the burner on or off depending on the maximum temperature set for the combustion chamber. This prevents overheating of the combustion chamber so that the safety thermostat L2 is not triggered. If the safety thermostat was triggered, the device would be switched off (see also chapter "Errors and faults").

The default thermostat setting for the maximum temperature of the combustion chamber is 95 °C with a hysteresis of 5 °C.

The "OUT 2" LED (34) indicates the operating condition of the burner thermostat: The LED sequence "-" (33), "=" (32) and "+" (31) indicates the current temperature:

- If the red arrow above the "-" (33) symbol lights up, the temperature is below the set value. The burner is activated by the thermostat.
- If the green LED above the "=" (32) symbol lights up, the temperature corresponds to the set nominal value.
- If the red arrow above the "+" (31) symbol lights up, the temperature is above the set value. The burner is locked by the thermostat.

The trigger temperature of the fan thermostat and the burner thermostat can only be modified after consultation with the Trotec customer service.

- Never carry out more than two consecutive restarts: Unburned fuel oil can accumulate in the combustion chamber and might suddenly ignite during the subsequent restart.

### Ventilation

If you want to use the air heater for continuous ventilation only, set the Heating/ventilation switch (25) to operating mode **V**.

### Temperature controller

The air heater is equipped with a temperature controller (g) with LC display (36) that can be used to display and control the following parameters:

- Detection of the air outlet temperature
- Recording of the operating hours
- Control of the trigger temperature of the fan thermostat
- Control of the trigger temperature of the burner thermostat

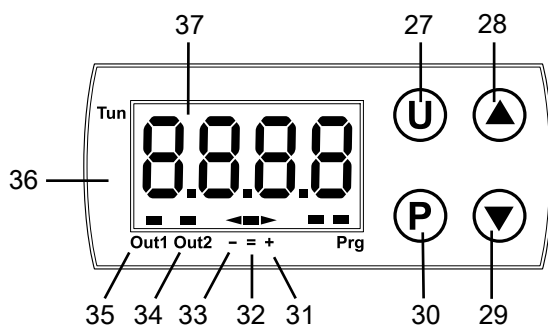

Proceed as follows to reset the counter:

1. Turn the Heating/ventilation switch (25) of the device to operating mode **0** (OFF).
2. Press and hold the **P** button (30) of the temperature controller for at least three seconds.
  - ⇒ The word "PASS" flashes for five seconds.
3. Enter the code "-481" by pressing the **▼** button (29) several times until the desired indication appears. Press the **P** button (30) to confirm and to move to the next indication.
4. Then press the **U** button (27).
  - ⇒ The air outlet temperature is displayed again.

**Shutdown**



**Warning of electrical voltage**

Do not touch the mains plug with wet or damp hands.

**Note**

Damage to the device due to overheating!  
 Never switch off the device by pulling the mains plug.  
 This may lead to overheating!  
 Switch off the device properly. Only remove the mains plug from the device once the fan motor has stopped completely.

1. Set the Heating/ventilation switch (25) to **0**.

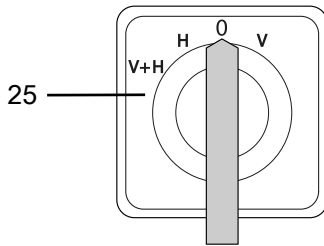

⇒ The burner stops (burner indicator light (20) goes out) while the fan is in operation. The fan switches on and off several times until the combustion chamber has cooled down completely.

Observe the following:

- Never pull the plug out of the supply control panel to stop the operation of the air heater. The electrical supply may only be interrupted after the fan has come to a standstill.

**Disconnecting the oil supply**

Proceed as follows to disconnect the oil supply:

- ✓ Make sure that there is no fuel residue in the feed and return hose.
  - ✓ Switch the device off according to the Shutdown chapter.
  - ✓ Allow the device to cool down completely.
1. Remove the feed and return hose from the tank connection of the external tank.
  2. Remove the feed and return hose from the tank connection (12) of the device.

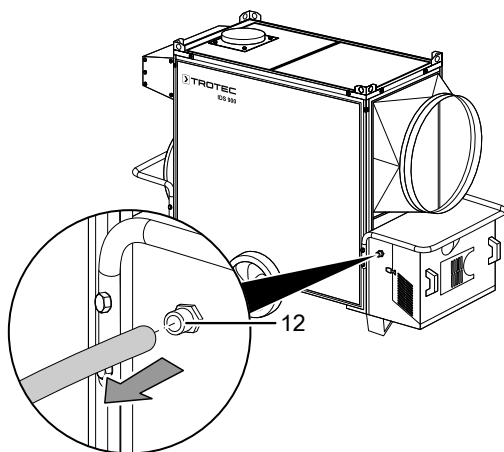

3. Reattach the cover of the external tank to the tank connection of the tank.
4. Reattach the cover of the device to the tank connection (12) of the device.

**Available accessories**

Designation	Article number
Two-way hose distributor 2 × Ø 600 mm	6100006174
Four-way hose distributor 4 × Ø 400 mm	6100006175
Thermostat with 10 m cable	6100007016
Oil pre-heating	6100006177
Filler neck oil filter	6100006161
Oil tank pedestal IDS 900, capacity 208 litres	6100006176
Exhaust gas pipe rigid, length 1 m	6100006214
90° arc connection for exhaust gas pipe	6100006220
Exhaust gas pipe rain cover	6100006226
Air hose Tronect SP-C <sup>3</sup> , length 7.6 m	6100001273

## Errors and faults



### Warning of electrical voltage

Tasks which require the device to be opened must only be carried out by authorised specialist companies or by Trotec.



### Warning

Risk of injury due to improper repair!

Never try to make any modifications or repairs on the device.

Unauthorised modifications can lead to serious injuries or death.

Have a certified specialist workshop perform the repair work.

The device has been checked for proper functioning several times during production. If malfunctions occur nonetheless, check the device according to the following list.

### The device does not start:

- Check the power connection.
- Check the power cable and mains plug for damage. If you notice damages, do not try to take the device back into operation.

If the supply cord is damaged, it must be replaced by the manufacturer, its service agent or similarly qualified persons in order to avoid a hazard.

- Check the on-site fusing.

### Note

Wait for at least 10 minutes after maintenance and repair work. Only then switch the device back on.

### The device still does not operate correctly after these checks:

Please contact the customer service. If necessary, bring the device to an authorised specialist electrical company or to Trotec for repair.

## Error codes

The following error messages can be displayed on the segment display:

- **Fault on the control box**

The red block signal lights up if the safety thermostat L2 (19) is triggered: Press the burner reset button (24). The reset button and the lamp (24) are located inside the burner housing. Slide the cover of the reset button to the side to access the reset button from the outside.

- **Fault on the burner**

The burner indicator light (20) lights up as a result of the burner flame monitoring being triggered. In the event of a safety shutdown, never carry out two consecutive restarts.

Unburned fuels can accumulate in the combustion chamber and might suddenly ignite during the subsequent restart.

- **Inspections and measures do not produce any results:**  
Contact the Trotec customer service.

Malfunction	Meaning	Remedy
Device does not start/device switches off	No power supply	Check the functioning and position of the Heating/ventilation switch (25)
		Check the characteristics of the electrical line
		Check whether the fuses are intact
	Heating/ventilation switch (25) is not set to the correct position	Set to the correct position
	Room thermostat operates irregularly	Check and correct the thermostat position
Check whether the thermostat is operational		
	The safety system (burner, thermostat L2, thermal relay of the fan) was not reset after repair	Please proceed as follows: <ul style="list-style-type: none"> <li>• Press the burner reset button (24)</li> <li>• Press the burner button (button on control system)</li> <li>• Press the button for the safety thermostat with manual reset (21)</li> <li>• Press the thermal relay of the fan</li> </ul>
Tripping of thermostat L1	Overheating of the combustion chamber	Check fuel supply
		Check the correct positioning of flaps, supports etc.
		Remove dirt/foreign objects from the air ducts and ventilation grilles
Tripping of thermostat L2 (warning light (19) lights up)	Overheating of the combustion chamber	Check fuel supply
		Check the correct positioning of flaps, supports etc.
		Remove dirt/foreign objects from the air ducts and ventilation grilles
Tripping of thermal relay RM (lamp (18) lights up)	Overheating of the combustion chamber	Heater with axial fan: Remove any obstacles from the air inlet. Reduce the lengths of the air ducts
		Heater with centrifugal fan: Check the fan belt setting
		In any case, check that the power consumption of the air motor is lower than the value indicated on the nameplate
The burner starts, the flame does not ignite and the reset indicator and the control system is illuminated	Irregular operation of the burner	Should this situation reoccur after pressing the burner reset button (24) and after restarting the device, please contact the technical customer service.

The fan does not start or starts with a delay	No power supply	Check whether the fuses are intact Check the electrical connections
	Thermostat (21) damaged	Check, adjust or exchange the thermostat
	Motor winding burnt or interrupted	Exchange fan and motor
	Motor capacitor burnt (Mod. "M")	Exchange capacitor
	Motor bearing blocked	Exchange bearing
The fan makes noises or vibrates	Foreign object on air inlet	Remove foreign objects and dirt
	Insufficient air circulation	Remove foreign objects and dirt
Insufficient heating	Insufficient heat output of the burner	Please contact the technical customer service.

**Maintenance**
**Maintenance intervals**

Maintenance and care interval	before every start-up	as needed	at least every 2 weeks	at least every 4 weeks	at least every 6 months	at least annually
Check air inlets and outlets for dirt and foreign objects and clean if necessary	X					
Check air inlet grid(s) for dirt and foreign objects and clean if necessary	X		X			
Clean the exterior		X				X
Visually check the inside of the device for dirt		X		X		
Check for damage	X					
Check attachment screws		X				X
Check the thermostats					x	
Check the electrical connections					x	
Clean the motor and fan	x	x				
Checking and testing the burner		x				x
Clean combustion chamber		x				x
Check fuel oil supply line	x					
Check the air heater	x					
Clean heat exchanger		x				x
Clean the interior					x	
Test run						X



## Maintenance and care log

Device type: .....

Device number: .....

Maintenance and care interval	1	2	3	4	5	6	7	8	9	10	11	12	13	14	15	16
Check air inlets and outlets for dirt and foreign objects and clean if necessary																
Check air inlet grid(s) for dirt and foreign objects and clean if necessary																
Clean the exterior																
Visually check the inside of the device for dirt																
Check for damage																
Check attachment screws																
Check the thermostats																
Check the electrical connections																
Clean the motor and fan																
Checking and testing the burner																
Clean combustion chamber																
Check fuel oil supply line																
Check the air heater																
Clean heat exchanger																
Clean the interior																
Test run																
Comments																

1. Date: .....	2. Date: .....	3. Date: .....	4. Date: .....
Signature: .....	Signature: .....	Signature: .....	Signature: .....
5. Date: .....	6. Date: .....	7. Date: .....	8. Date: .....
Signature: .....	Signature: .....	Signature: .....	Signature: .....
9. Date: .....	10. Date: .....	11. Date: .....	12. Date: .....
Signature: .....	Signature: .....	Signature: .....	Signature: .....
13. Date: .....	14. Date: .....	15. Date: .....	16. Date: .....
Signature: .....	Signature: .....	Signature: .....	Signature: .....

**Activities required before starting maintenance**



**Warning of electrical voltage**

Do not touch the mains plug with wet or damp hands.

- Switch the device off.
- Hold onto the mains plug while pulling the power cable out of the mains socket.
- Allow the device to cool down completely.



**Warning of electrical voltage**

**Tasks which require the device to be opened must only be carried out by authorised specialist companies or by Trotec.**

**Cleaning and testing**

Proceed as follows for all cleaning and maintenance work:

- Switch the device off as described in the Shutdown chapter.
- Wait until the device has cooled down completely.

**Note**

Regularly check the care and maintenance protocol.

**The following maintenance and care activities must be carried out by the customer service:**

**Checking and testing the burner**

- Dismantle and inspect the burner (43) according to the supplier's instructions of the burner.
- Carry out all action steps to measure the combustion parameters and to make sure that the combustion is stable and clean (see chapter Commissioning).

**Cleaning the heat exchanger, burner and combustion chamber**

- Dismantle the burner (43) and the turbulence systems (39).
- Clean the burner (43), the turbulence systems (39), the heat exchanger (38) and the combustion chamber (42).

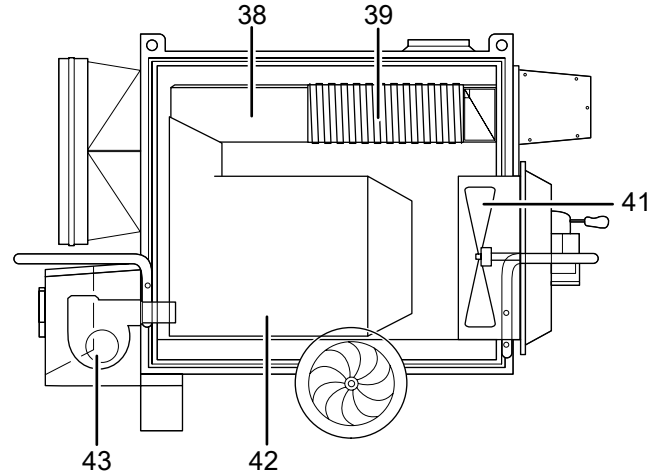

**Clean the motor and fan**

- Dismantle the fan (41) and clean the fan wheel.
- Clean the motor with compressed air.

**The following maintenance and care activities must be carried out by the operator:**

**Checking the air heater and the fuel oil supply line**

Please ensure that:

- the room to be heated is sufficiently ventilated
- the air intake and outlet pipes are not blocked
- there are no sheets or blankets on the device
- that the device is in a stable position
- the device is not positioned in areas with a high risk of fires or in potentially explosive atmospheres
- a safety distance from flammable substances is maintained

In case of fuel oil leaks, please proceed as follows:

1. Close the fuel oil stopcock.
2. Locate the fuel oil leaks.
3. Call the Trotec customer service.

### Cleaning the exterior

Clean the following device parts from the exterior:

- Burner
  - Thoroughly remove dirt and residues
  - Make sure that the air inlet is not clogged
- Clean the housing, lines, pipes, connectors and joints with a cloth
- Air inlet/outlet:
  - Thoroughly remove dirt and residues
  - Make sure that the air inlet is not clogged

Also pay attention to the following when cleaning the exterior and interior:

- The maximum permissible pressure is 70 bar with a distance below 30 cm
- All parts are completely dry before the power cable is reconnected

### Check the electrical connections

Proceed as follows to check the electrical connections:

1. Pull the power cable from the socket.
2. Make sure that the connections are intact and properly seated.
3. Remove any dirt and residues.
4. If necessary, have intact connections, wires or plug connectors replaced by the Trotec customer service.

### Check the thermostats

Proceed as follows to check the thermostats:

1. Remove any connection ducts from the air outlet.
2. Locate the thermostats mounted on the inner wall of the air heater.
3. Clean the thermostats with a dry cloth and pay attention not to kink or damage the capillary tube

## Technical annex

### Technical data

Parameter	Value								
Model	IDS 900								
Combustion	indirect								
Max. nominal heat input	236 kW								
Nominal heat output	217 kW								
Amount of air	17000 m <sup>3</sup> /h								
Temperature increase	55 °C								
Max. fuel consumption	21.69 l/h								
Mains connection	230 V / 50 Hz								
Current consumption	11.2 A								
Overheating protection	yes								
Air transport hose (SP-C)	Ø 725 mm								
Sound pressure level (distance 1 m)	69 dB(A)								
Dimensions (length x width x height)	2245 × 982 × 1584 mm								
Minimum distance to walls or other objects	<table style="margin-left: auto; margin-right: auto;"> <tr> <td>top</td> <td>2 m</td> </tr> <tr> <td>rear</td> <td>2 m</td> </tr> <tr> <td>sides</td> <td>2 m</td> </tr> <tr> <td>front</td> <td>2 m</td> </tr> </table>	top	2 m	rear	2 m	sides	2 m	front	2 m
top	2 m								
rear	2 m								
sides	2 m								
front	2 m								
Weight (with empty tank)	351 kg								
<b>Burner (see operating manual of the burner)</b>									
Fuel oil pressure of the burner	13 bar								
Burner head position	position 6								
Adjusting the air volume with hose	position 8.0								
without hose	position 7.3								

### Fuels

Only the following fuel types with the specifications 10,200 kcal/kg, max. and viscosity 1.5°E at 20 °C are permitted for the device:

- Diesel fuel (10 % biodiesel maximum)
- Kerosene

**Wiring diagram IDS 900**

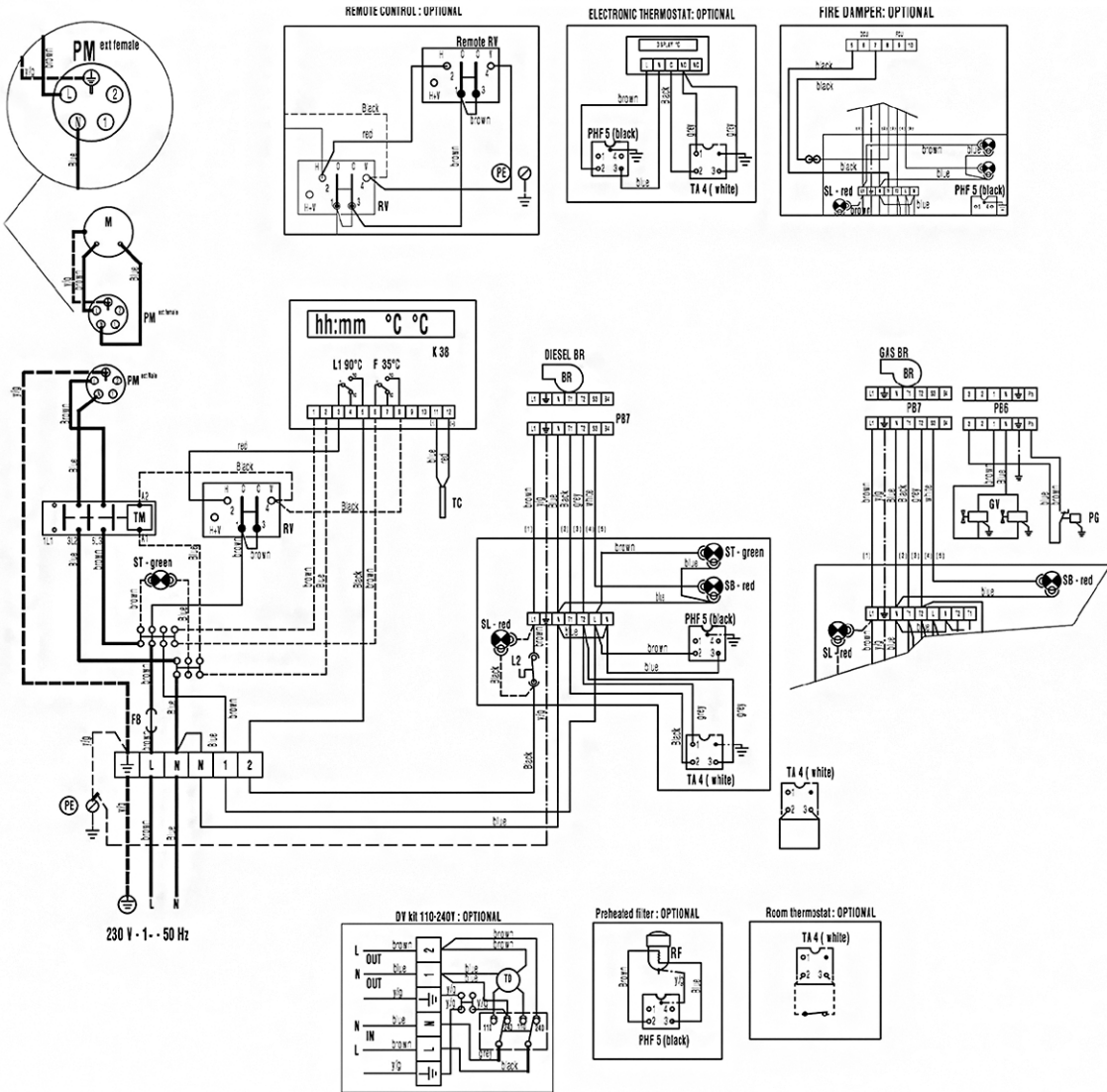

<b>C</b> Capacitor	<b>TM</b> Remote switch for fan	<b>BR</b> Burner	<b>L2</b> Safety thermostat with manual release, L2
<b>M</b> Fan motor	<b>RM</b> Thermal relay for fan	<b>TA</b> Room thermostat	<b>RV</b> Switch heating-stop-ventilation
<b>F</b> Air controller	<b>ST</b> Indicator light	<b>PB</b> Burner	<b>SL</b> Overheating protection indicator light, L1, L2
<b>FB</b> Fuse for burner 6A	<b>SB</b> Fan "OFF" indicator light	<b>L1</b> Overheating protection thermostat, L1	

**Overview of spare parts IDS 900**

**Note!**

The position numbers of the spare parts differ from those describing the positions of the components mentioned in these instructions.

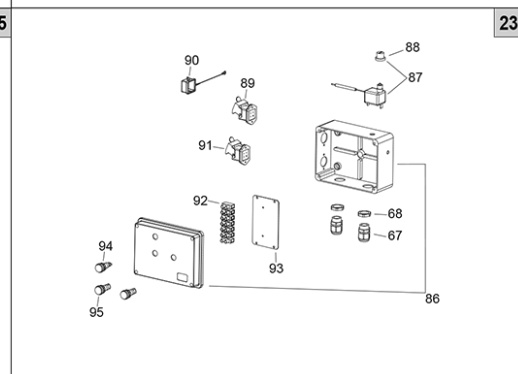
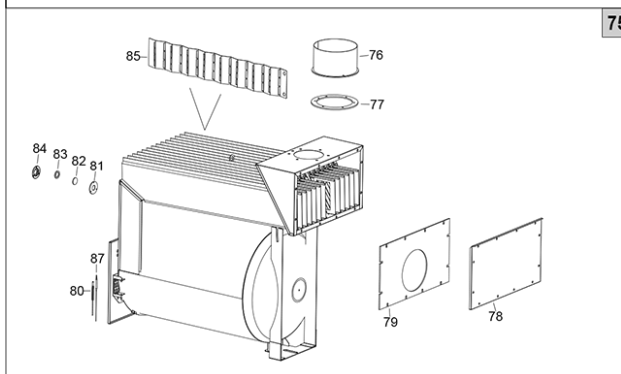
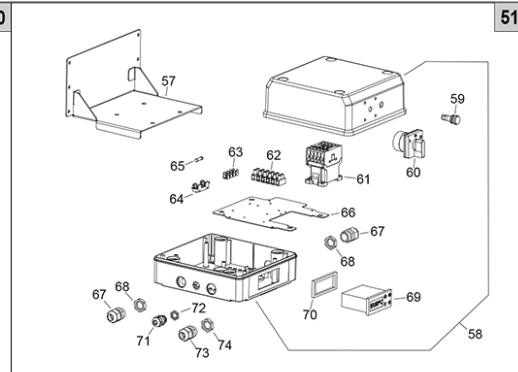
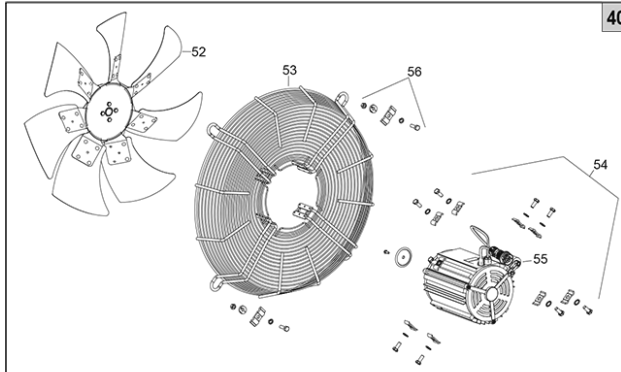
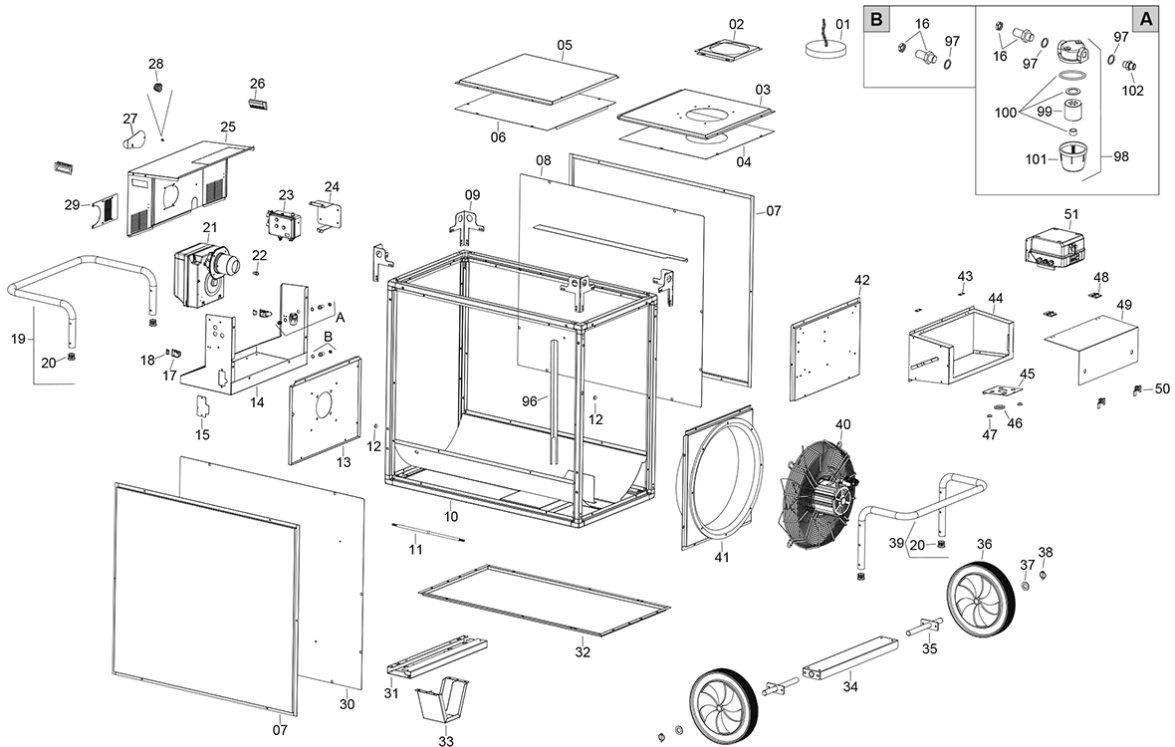

No.	SPARE PART	No.	SPARE PART	No.	SPARE PART
1	Cap	35	Wheel axle	69	Thermoregulator
2	Panel	36	Wheel	70	Seal
3	Panel	37	Washer	71	Cable fastener
4	Panel	38	Latched pin	72	Cable fastener nut
5	Panel	39	Bumper	73	Cable fastener
6	Panel	40	Air fan assembly	74	Cable fastener nut
7	Panel	41	Panel	75	Combustion chamber
8	Panel	42	Support bracket	76	Chimney fitting
9	Stirrup	43	Spacer	77	Seal
10	Frame	44	Electrical panel box	78	Panel
11	Power cord	45	Support plate	79	Insulating gasket
12	Cable protection	46	Cable protection	80	Thermocouple
13	Panel	47	Cable protection	81	Insulating gasket
14	Base	48	Hinge	82	Tempered glass
15	Panel	49	Panel	83	Insulating gasket
16	Fitting	50	Lock	84	Disc
17	Toggle latch	51	El. control box	85	Turbulence-generating grid
18	Catch	52	Fan	86	El. components box
19	Handle	53	Inlet grill	87	Safety thermostat
20	Cap	54	Motor	88	Safety thermostat plastic profile
21	Oil burner	55	Capacitor	89	Plug
22	Nozzle	56	Hardware kit (screws/nuts/ washers)	90	Thermostat plug cover
23	El. control box	57	Stirrup	91	Thermostat plug
24	Thermostat support bracket	58	El. components box	92	Terminal board
25	Panel	59	Lamp	93	Support plate
26	Handle	60	Switch	94	Lamp
27	Panel	61	Contacto	95	Lamp
28	Spring	62	Terminal board	96	Protective panel
29	Panel	63	Ground terminal board	97	Aluminium washer
30	Panel	64	Fuse holder	98	Diesel filter
31	Support bracket	65	Fuse	99	Filter cartridge
32	Panel	66	Support plate	100	Filter seal kit
33	Support	67	Cable fastener	101	Filter container
34	Wheels axle support bracket	68	Cable fastener nut	102	Iron fitting



## Disposal



The icon with the crossed-out waste bin on waste electrical or electronic equipment stipulates that this equipment must not be disposed of with the household waste at the end of its life. You will find collection points for free return of waste electrical and electronic equipment in your vicinity. The addresses can be obtained from your municipality or local administration. You can also find out about other return options that apply for many EU countries on the website <https://hub.trotec.com/?id=45090>. Otherwise, please contact an official recycling centre for electronic and electrical equipment authorised for your country.

The separate collection of waste electrical and electronic equipment aims to enable the re-use, recycling and other forms of recovery of waste equipment as well as to prevent negative effects for the environment and human health caused by the disposal of hazardous substances potentially contained in the equipment.

### Fuel oil

The fuel oil must be drained from the device and collected. Fuels are to be disposed of according to the national regulations.

## Declaration of conformity

Declaration of conformity in accordance with the EC Machinery Directive 2006/42/EC, Annex II, Part 1, Section A

We – Trotec GmbH – declare in sole responsibility that the product designated below was developed, constructed and produced in compliance with the requirements of the EC Machinery Directive in the version 2006/42/EC.

**Product model / Product:** IDS 900

**Product type:** oil heater

**Year of manufacture as of:** 2021

### Relevant EU directives:

- 2014/30/EU: 29/03/2014

### Applied harmonised standards:

- None

### Applied national standards and technical specifications:

- None

### Manufacturer and name of the authorised representative of the technical documentation:

Trotec GmbH  
Grebener Straße 7, D-52525 Heinsberg  
Phone: +49 2452 962-400  
E-mail: [info@trotec.de](mailto:info@trotec.de)

Place and date of issue:  
Heinsberg, 02.11.2021



Detlef von der Lieck, Managing Director

Trotec GmbH

Grebbener Str. 7  
D-52525 Heinsberg

☎ +49 2452 962-400

☎ +49 2452 962-200

✉ [info@trotec.com](mailto:info@trotec.com)

[www.trotec.com](http://www.trotec.com)