



MASTER
CLIMATE SOLUTIONS













MCS Italy S.p.A. Via Gardesana 11, 37010- Pastrengo (VR), Italy info@mcsitaly.it	MCS Italy S.p.A. Виа Гардесана 11, 37010 Пастренго (Верона), Италия info@mcsitaly.it
MCS Central Europe Sp. z o.o. ul. Magazynowa 5A, 62-023 Gądkki, Poland office@mcs-ce.pl	MCS Central Europe Sp. z o.o. ул. Магазинова, 5А, 62-023 Гадки, Польша office@mcs-ce.pl
MCS Russia LLC ul. Transportnaya - 22 ownership 2, 142802, STUPINO, Moscow region, Russia info@mcsrussia.ru	ООО «ЭмСиЭс Россия» Ул. Транспортная, владение 22/2, 142802, г.Ступино, Московская обл., РФ info@mcsrussia.ru
MCS China LTD Unit 2B, 512 Yunchuan Rd., Shanghai, 201906, China office@mcs-china.cn	MCS China LTD Юньчуань роад, 512, строение 2В, Шанхай, 201906, Китай office@mcs-china.cn
EURITECSA C/Calabozos, 6 Poligono Industrial, 28108 Alcobendas (Madrid) Spain euritecsa@euritecsa.es	EURITECSA Ц/Калабозос, 6 Полигоно Индустриал, 28108 Алкобендас (Мадрид) Испания euritecsa@euritecsa.es

USER AND MAINTENANCE BOOK	en
LIBRETTO USO E MANUTENZIONE	it
BEDIENUNGS- UND WARTUNGSANLEITUNG	de
MANUAL DE INSTRUCCIONES PARA EL USO Y MANTENIMIENTO	es
MANUEL D'UTILISATION ET DE MAINTENANCE	fr
HANDLEIDING VOOR GEBRUIK EN ONDERHOUD	nl
MANUAL DE USO E MANUTENÇÃO	pt
VEJLEDNING OM BRUG OG VEDLIGEHOLDELSE	da
KÄYTTÖ- JA HUOLTO-OHJE	fi
HEFTE FOR BRUK OG VEDLIKEHOLD	no
ANVÄNDAR- OCH UNDERHÅLLSHANDBOK	sv
INSTRUKCJA OBSŁUGI I KONSERWACJI	pl
РУКОВОДСТВО ПО ЭКСПЛУАТАЦИИ И ТЕХНИЧЕСКОМУ ОБСЛУЖИВАНИЮ	ru
PRÍRUČKA PRO POUŽITÍ A ÚDRŽBU	cs
HASZNÁLATI ÉS KARBANTARTÁSI KÉZIKÖNYV	hu
PRIROČNIK Z NAVODILI ZA UPORABO IN VZDRŽEVANJE	sl
KULLANIM VE BAKIM KİTAPÇIĞI	tr
KNJIŽICA O UPORABI I ODRŽAVANJU	hr
NAUDOJIMO IR PRIEŽIŪROS KNYGELĖ	lt
LIETOŠANAS UN TEHNISKĀS APKOPEŠ GRĀMATIŅA	lv
KASUTUS- JA HOOLDUSJUHEND	et
MANUAL DE UTILIZARE ŞI ÎNTREȚINERE	ro
PRÍRUČKA PRE POUŽITIE A ÚDRŽBU	sk
НАРЪЧНИК ЗА ИЗПОЛЗВАНЕ И ПОДДРЪЖКА	bg
КЕРІВНИЦТВО З ЕКСПЛУАТАЦІЇ Й ТЕХНІЧНОГО ОБСЛУГОВУВАННЯ	uk
KNJIŽICOM O UPOTREBI I ODRŽAVANJU	bs
ΕΓΧΕΙΡΙΔΙΟ ΧΡΗΣΗΣ ΚΑΙ ΣΥΝΤΗΡΗΣΗΣ	el
使用和维护手册	zh
ПАЙДАЛАНУ ЖӨНЕ ТЕХНИКАЛЫҚ ҚЫЗМЕТ КӨРСЕТУ ЖЕТЕКШІЛІГІ	kk

XL 91

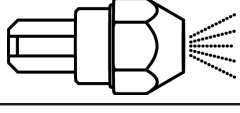
TECHNICAL DATA TABLE - TABELLA DATI TECNICI - TECHNISCHE DATENTABELLE - TABLA DE DATOS TÉCNICOS - TABLEAU DES DONNÉES TECHNIQUES - TABEL TECHNISCHE GEGEVENS - TABELA DE DADOS TÉCNICOS - TEKNISK DATATABEL - TEKNISTEN TIETOJEN TAULUKKO - TABELL FOR TEKNISKE DATA - TABELL MED TEKNISKA EGENSKAPER - TABELA DANYCH TECHNICZNYCH - ТАБЛИЦЕ ТЕХНИЧЕСКИХ ДАННЫХ - TABULKA TECHNICKÝCH ÚDAJŮ - MŰSZAKI ADATOK TÁBLÁZATA - TEHNIČNI PODATKI - TEKNİK VERİLER TABLOSUNDA - TABLICI S TEHNIČKIM PODACIMA - TECHNINIŲ DUOMENŲ LENTELĖJE - TEHNISKO DATU TABULA - TEHNILISTE ANDMETE TABEL - TABELUL CU DATE TEHNICE - TABUĽKA TECHNICKÝCH ÚDAJOV - ТАБЛИЦА ТЕХНИЧЕСКИ ДАНИИ - ТАБЛИЦІ ТЕХНІЧНИХ ДАНИХ - TABELI SA TEHNIČKIM PODACIMA - ΠΙΝΑΚΙΔΑ ΤΩΝ ΤΕΧΝΙΚΩΝ ΣΤΟΙΧΕΙΩΝ - 技术参数 - ТЕХНИКАЛЫҚ КӨРСЕТКІШТЕР КЕСТЕСІ

MODEL	XL 91	
		
	29 kW-кВт 25.000 kcal/h-ккал/ч 99.300 Btu/h-БТЕ/ч	43 kW-кВт 37.000 kcal/h-ккал/ч 146.900 Btu/h-БТЕ/ч
	2,3 kg/h-кг/ч	3,37 kg/h-кг/ч
	DIESEL-KEROSENE дизель-керосин	
	55 л-л	
	~220-240 V-B (-15% ÷ +10%) 50-60 Hz-Гц 0,7 A	
	52 kg-кг	
	0,75 GpH 80°S LE DANFOSS	
	900 kPa-кПа 9 bar-бар	1300 kPa-кПа 13 bar-бар

 **IMPORTANT:** In order to have a correct function you must use an electrical generator in class G3 or more (frequency variation $\pm 1\%$, tension variation $\pm 2\%$). The maximum power of electrical generator must be three time the nominal power of device that you must connect.

PICTURES - FIGURE - ABBILDUNGEN - FIGURAS - FIGURES - FIGUREN - FIGURAS - FIGURER - KUVAT - FIGURER - FIGUR - RYSUNKI - РИСУНКИ - OBRÁZKY - ÁBRÁK - SLIKE - ŞEKİLLER - SLIKE - PAVEIKSLĖLIAI - ΑΤΤĒΛΙ - JOONISED - IMAGINI - OBRÁZKY - ФИГУРА - МАЛЮНКИ - SLIKE - ΕΙΚΟΝΕΣ - 图 - СУРЕТТЕР

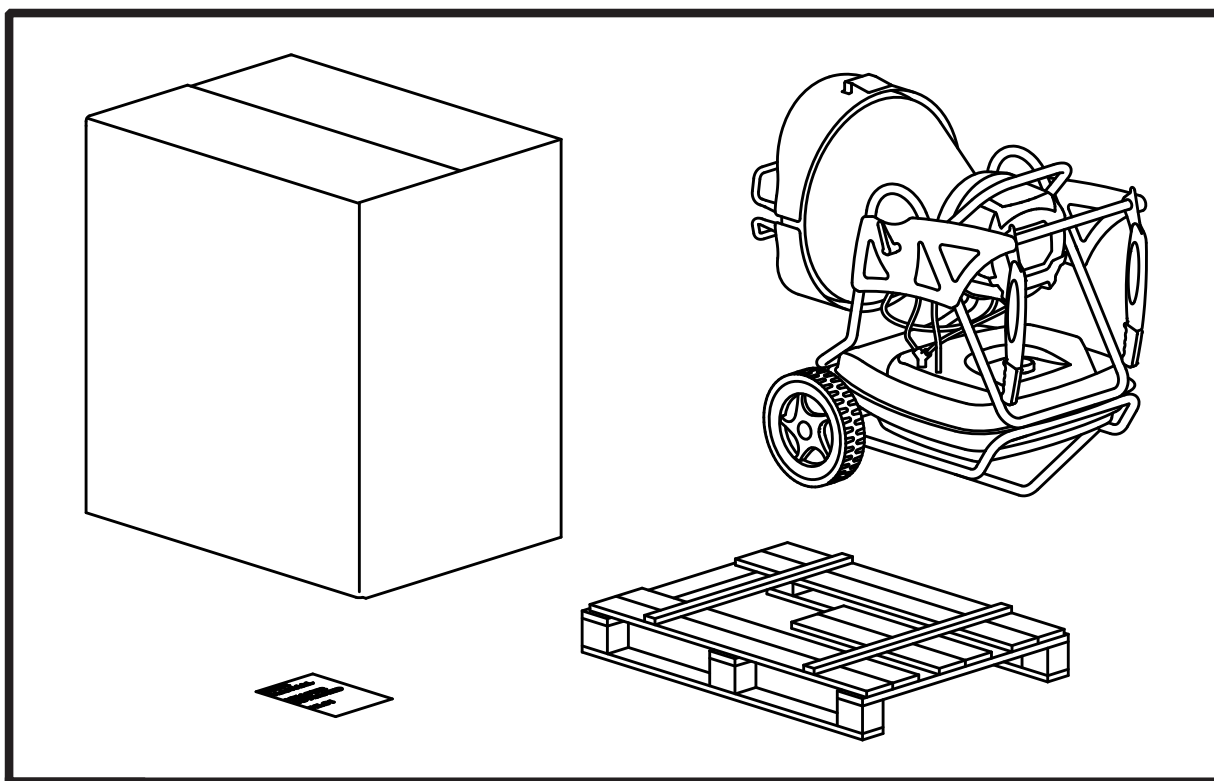

1

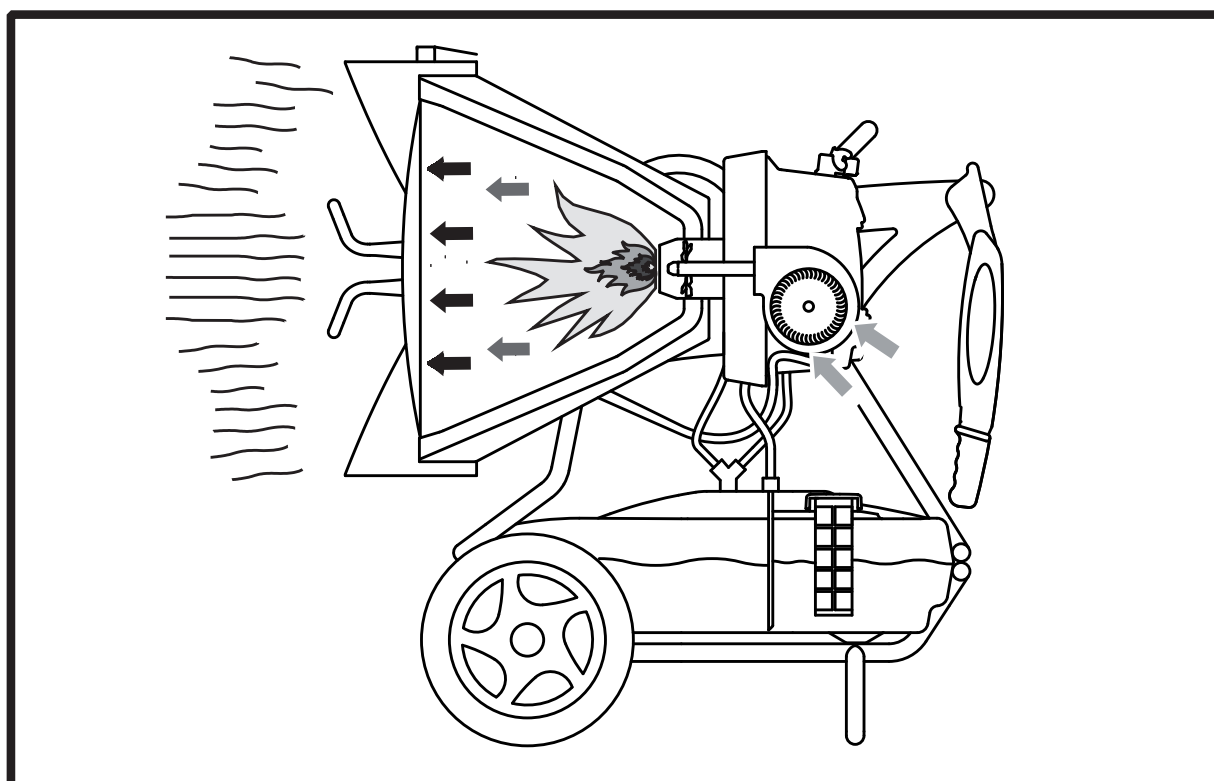

2

**PICTURES - FIGURE - ABBILDUNGEN - FIGURAS - FIGURES - FIGU-
REN - FIGURAS - FIGURER - KUVAT - FIGURER - FIGUR - RYSUN-
KI - РИСУНКИ - OBRÁZKY - ÁBRÁK - SLIKE - ŞEKİLLER - SLIKE
- PAVEIKSLĖLIAI - ΑΤΤΕΛΙ - JOONISED - IMAGINI - OBRÁZKY - ΦΙ-
ΓΥΡΑ - МАЛЮНКИ - SLIKE - EIKONES - ❏ - СУРЕТТЕР**

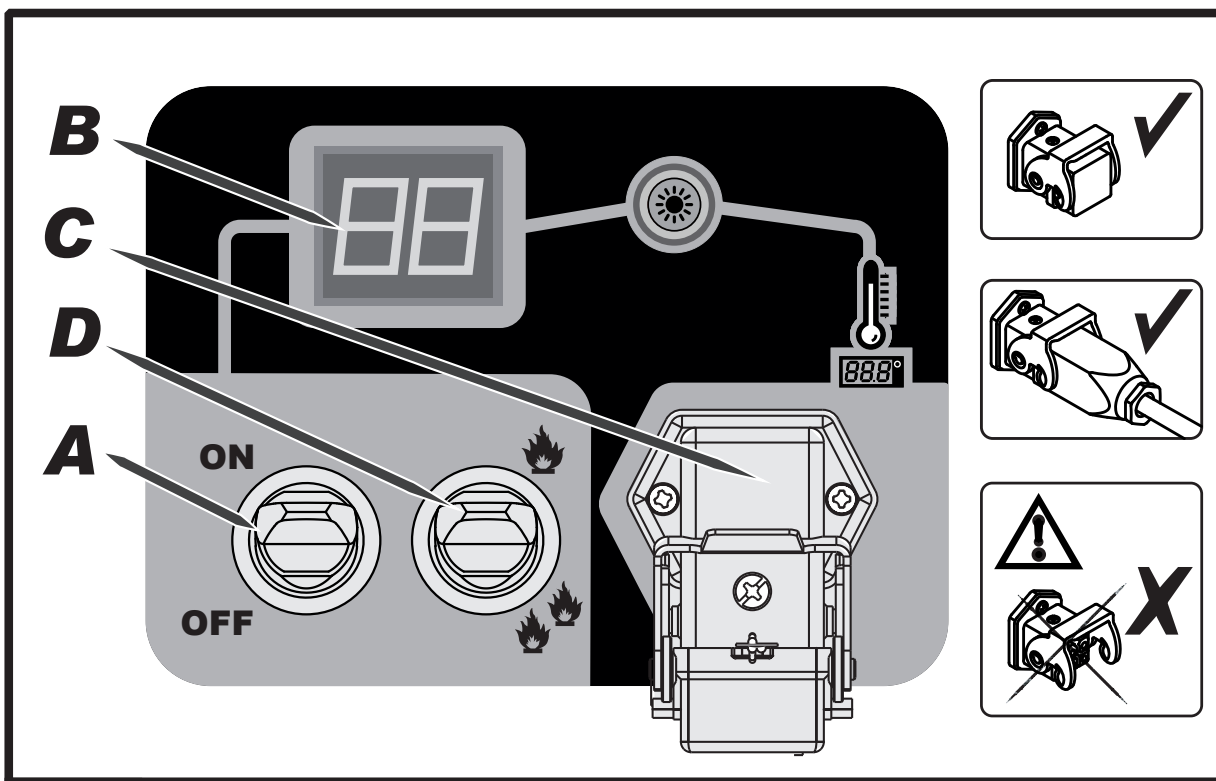

3

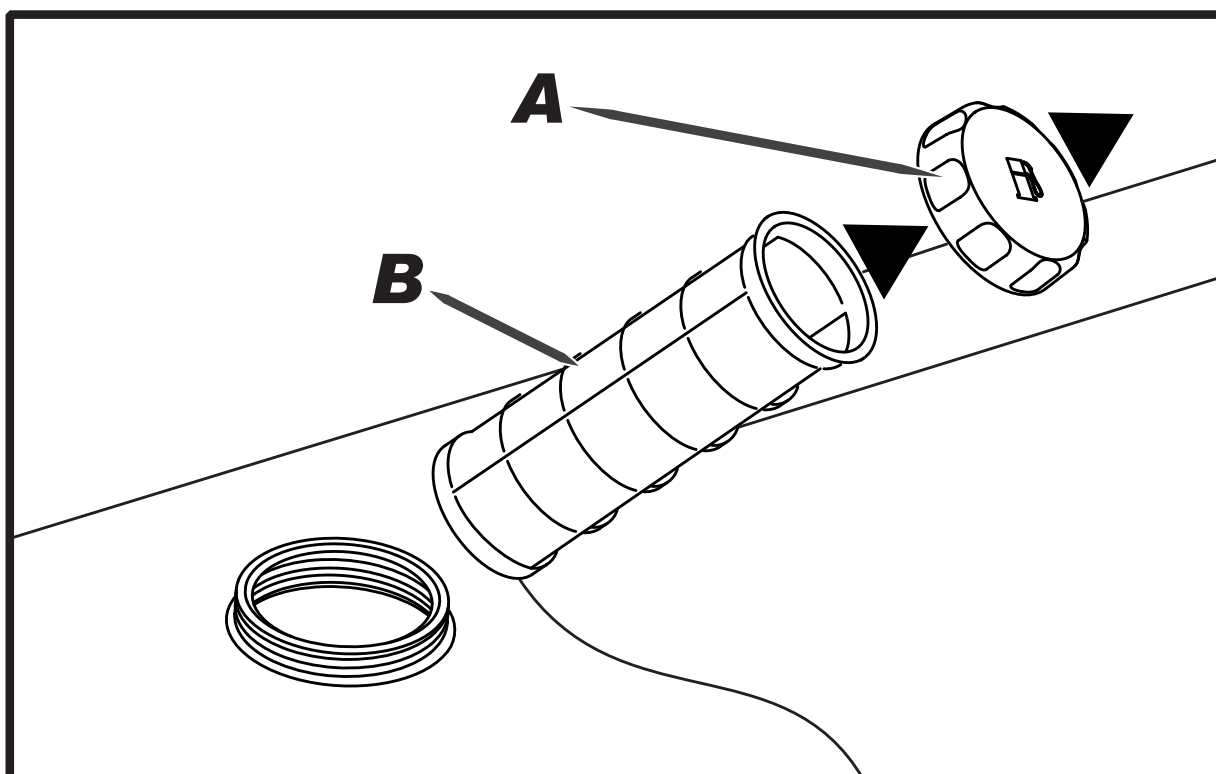

4

PICTURES - FIGURE - ABBILDUNGEN - FIGURAS - FIGURES - FIGUREN - FIGURAS - FIGURER - KUVAT - FIGURER - FIGUR - RYSUNKI - РИСУНКИ - OBRÁZKY - ÁBRÁK - SLIKE - ŞEKİLLER - SLIKE - PAVEIKSLĖLIAI - ΑΤΤĒΛΙ - JOONISED - IMAGINI - OBRÁZKY - ФИГУРА - МАЛЮНКИ - SLIKE - ΕΙΚΟΝΕΣ - 图 - СУРЕТТЕР

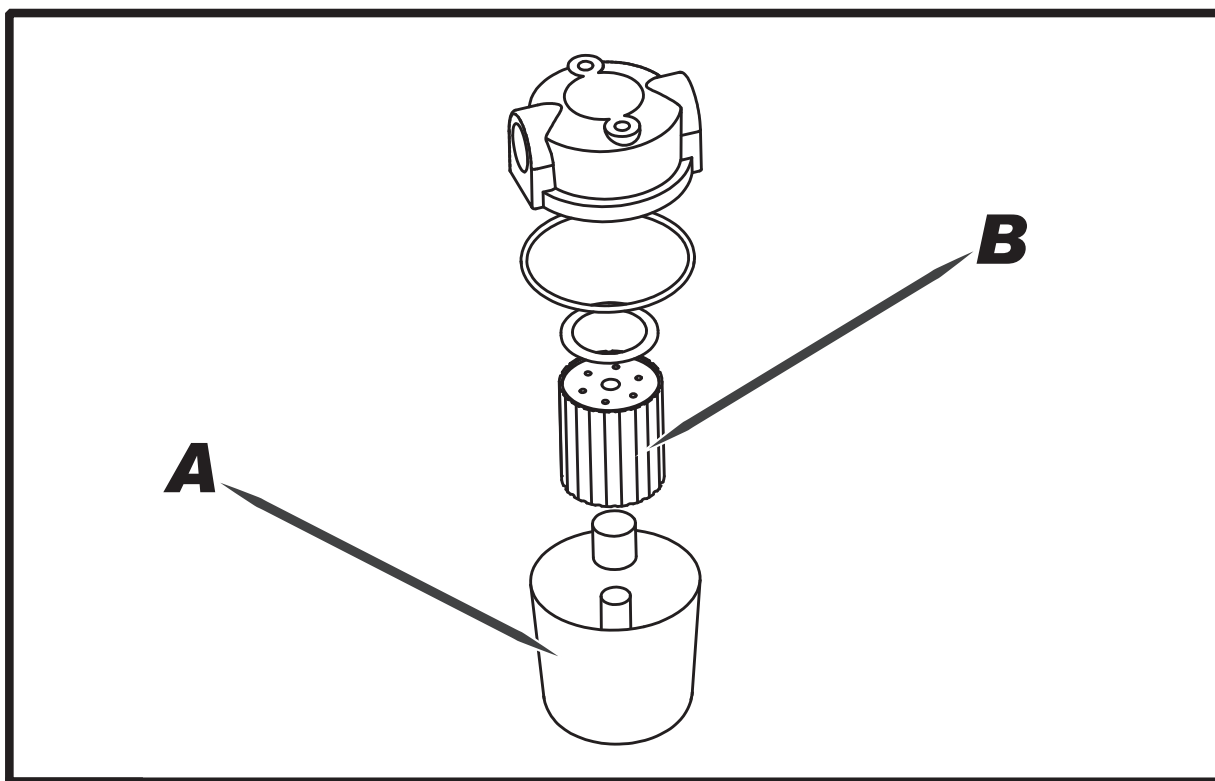

5

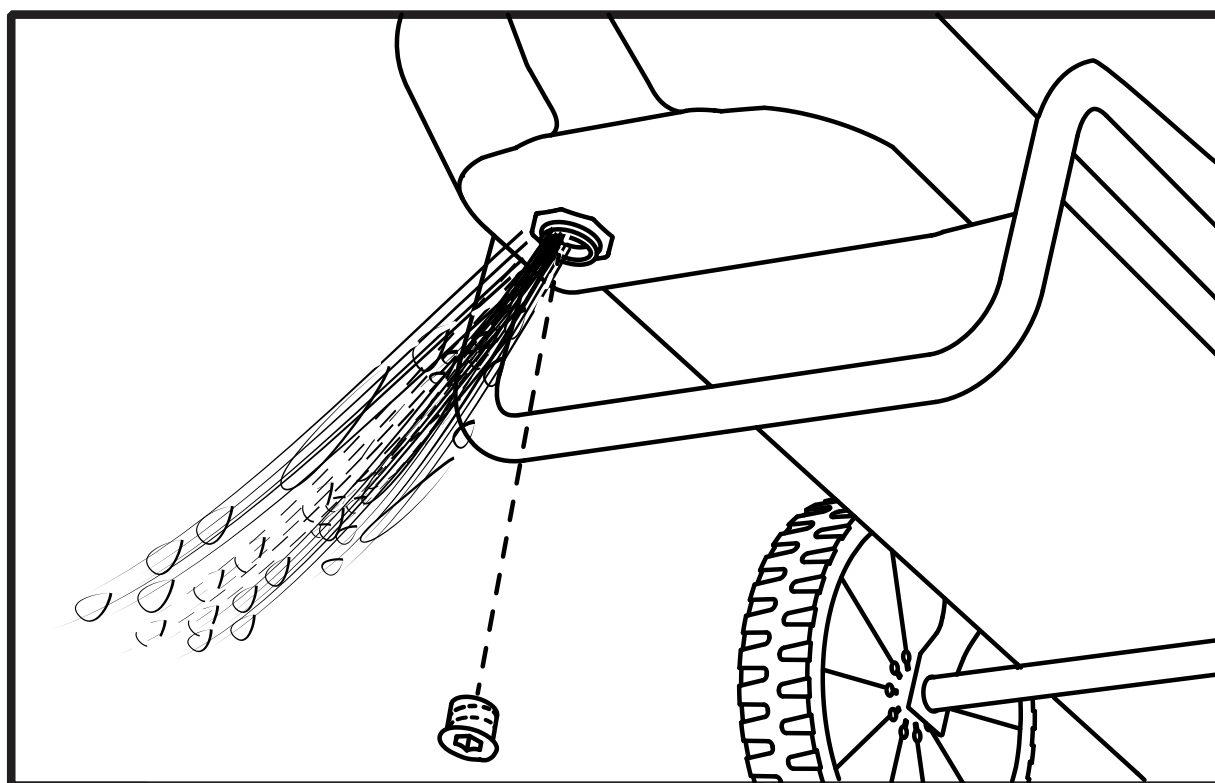

6

**PICTURES - FIGURE - ABBILDUNGEN - FIGURAS - FIGURES - FIGU-
REN - FIGURAS - FIGURER - KUVAT - FIGURER - FIGUR - RYSUN-
KI - РИСУНКИ - OBRÁZKY - ÁBRÁK - SLIKE - ŞEKİLLER - SLIKE
- PAVEIKSLĖLIAI - ΑΤΤΕΛΙ - JOONISED - IMAGINI - OBRÁZKY - ΦΙ-
ΓΥΡΑ - МАЛЮНКИ - SLIKE - EIKONES - ❏ - СУРЕТТЕР**

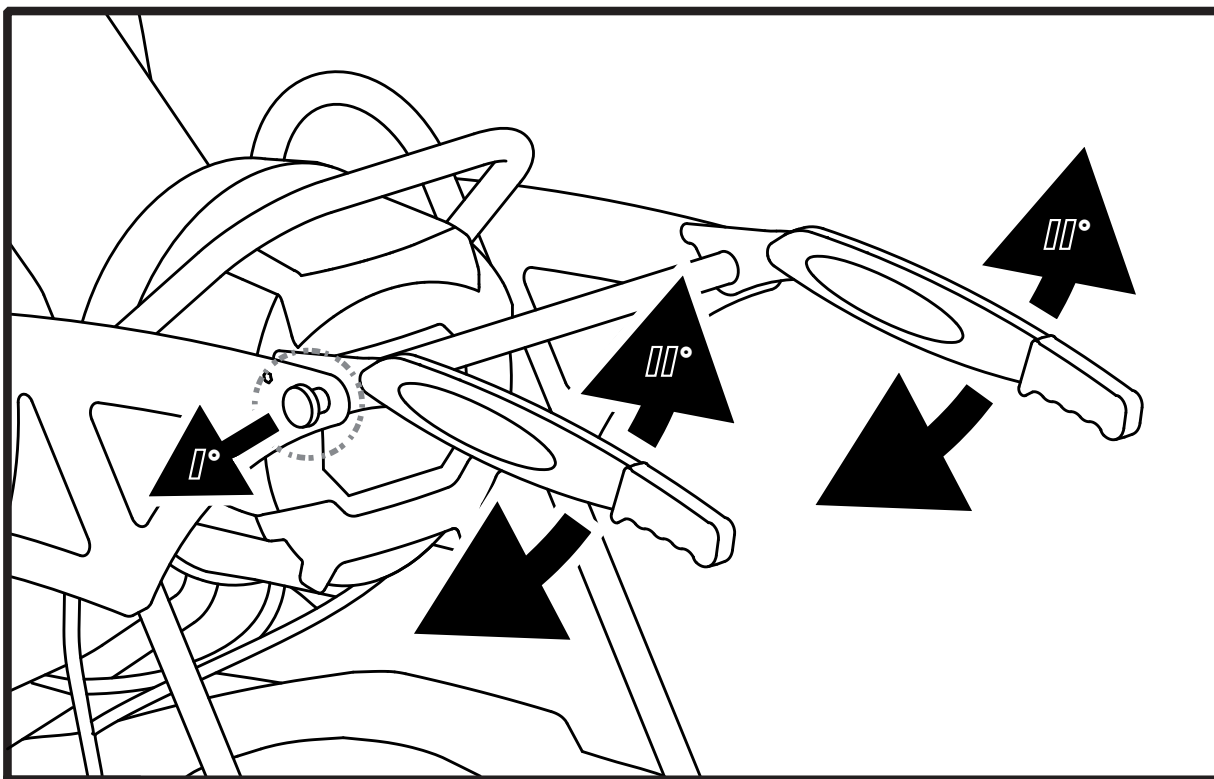

7

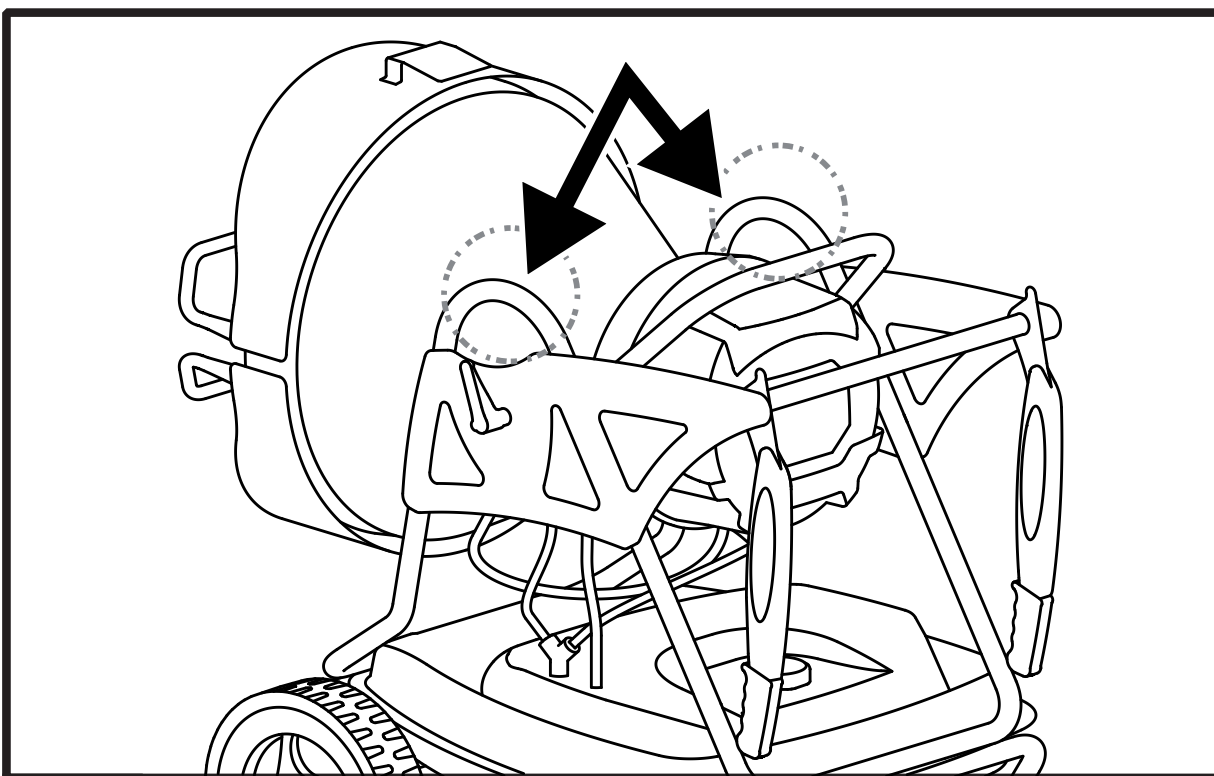

8

IMPORTANT: READ AND UNDERSTAND THIS OPERATIONAL MANUAL BEFORE PERFORMING ASSEMBLY, COMMISSIONING OR MAINTENANCE ON THIS HEATER. INCORRECT USE OF THE HEATER CAN CAUSE SERIOUS INJURY. KEEP THIS MANUAL FOR FURTHER REFERENCE.

▶▶ 1. SAFETY INFORMATION (WARNINGS)

⚠ IMPORTANT NOTICE: This device is not suitable for operation by persons (including children) with impaired physical, sensory or mental faculties, as well as inexperienced personnel, unless supervised by a safety guardian. Children are not to be left unattended as to ensure they are not playing with the equipment.

⚠ WARNING: Carbon monoxide poisoning can prove to be fatal.

First symptoms of carbon monoxide poisoning are similar to influenza with severe headaches, dizziness and/or nausea. Such symptoms may be caused by heater fault. UPON NOTICING THESE SYMPTOMS, IMMEDIATELY LEAVE THE ROOM AND GO OUTSIDE, next, notify the technical service center that the heater needs to be repaired.

1.1. SUPPLY:

- ▶ 1.1.1. Personnel in charge of supply must be fully qualified, must be familiar with the manufacturer's manual as well as the effective regulations for safe supply of heaters.
- ▶ 1.1.2. Only the fuel types specifically listed on the heater's nameplate are to be used.
- ▶ 1.1.3. Before refueling, shut down the heater and wait for it to cool down.
- ▶ 1.1.4. Fuel cisterns are to be located in a separate facility.
- ▶ 1.1.5. All fuel containers are to be located within safe distance from the heater, as per the applicable regulations.
- ▶ 1.1.6. Fuel is to be stored in rooms with insulated floor, so that the fuel cannot penetrate the floor into the open flame below causing fuel combustion.
- ▶ 1.1.7. Fuel storage needs to follow all the applicable regulations.

1.2. SAFETY CONSIDERATIONS:

- ▶ 1.2.1. The heater should never be used in rooms with fuel, paint thinners and other combustible fumes.
- ▶ 1.2.2. All applicable local rules and regulations need be observed while using the heater.

- ▶ 1.2.3. Heaters in operation near tarpaulin, screens or other similar materials need to be located a safe distance away. The use of inflammable covers is highly encouraged.
- ▶ 1.2.4. The device is to be used in well ventilated interiors only. To ensure proper air circulation, a proper opening is required, as per the applicable regulations.
- ▶ 1.2.5. For heater power feed observe closely the voltage and frequency values given on the nameplate.
- ▶ 1.2.6. Only use grounded, three-core extension cords.
- ▶ 1.2.7. Minimal safety distance between the heater and combustible materials is: front = 2,5 m (8 ft); side, up and back = 1,5 m (5 ft).
- ▶ 1.2.8. To avoid fire, hot or working heater is to be placed on a stable and leveled flooring.
- ▶ 1.2.9. Animals are to be kept at a safe distance away from the heater.
- ▶ 1.2.10. Unplug the heater at all times during downtime.
- ▶ 1.2.11. Thermostat control allows the heater to be turned on at any time.
- ▶ 1.2.12. The heater must not be used in frequently visited rooms and in bedrooms.
- ▶ 1.2.13. If the heater is plugged in, hot, or currently running, it must not be moved, manipulated, refueled or attempt maintenance work of any kind.
- ▶ 1.2.14. Keep the safe distance between the hot parts of the heater and thermosensitive or combustible materials (including feeder cable).
- ▶ 1.2.15. In case the feeder cable is damaged, have it replaced at the technical service center to avoid danger.

▶▶ 2. UNPACKING

See Fig. 1

- ▶ 2.1. Remove all the heater wrapping and packaging materials then dispose of them as per the applicable local regulations.
- ▶ 2.2. Remove all the components from the box.
- ▶ 2.3. Check for any damage during transport. If the heater appears damaged in any way, please inform your vendor promptly.

▶▶ 3. FUEL

⚠ WARNING: The heater only runs on DIESEL or KEROSENE fuel.

To avoid fire or explosion, use only diesel or kerosene fuel. Do not use gasoline, naphtha, paint thinners, alcohol or any other combustible liquids.

For low-temperature operation, use antifreeze supplements.

▶▶ 4. OPERATING PRINCIPLE

See Fig. 2

Airflow is necessary to ensure proper combustion, it is supplied by the internal burner fan. The air enters the burner funnel and gets mixed with a high-pressure fuel jet. The fuel flow is secured by an electrical pump, which sucks the fuel away from the tank and moves it to the nozzle under high pressure.

▶▶ 5. OPERATION

⚠ WARNING: Read the section "SAFETY CONSIDERATIONS" carefully before turning the heater on.

⚠ IMPORTANT: After the first time the heater does not switch on, make sure there is fuel in the tank, make sure the fuel filter is clean and make sure that the heater is positioned on a flat, stable surface.

⚠ IMPORTANT: This is a target infrared heater. Infrared heats bodies and not the air.

▶▶ 5.1. RUNNING THE HEATER:

- ▶ 5.1.1. Observe all safety instructions at all times.
- ▶ 5.1.2. Check if fuel is present in the tank.
- ▶ 5.1.3. Close the fuel tank filler plug.
- ▶ 5.1.4. Plug the feeder cable into the socket (CHECK THE VOLTAGE IN "TECHNICAL DATA SHEET").
- ▶ 5.1.5. Turn the "ON/OFF" switch "ON" (I) (A Fig. 3). The heater should be online in a few seconds. If it is not, please refer to the section "PROBLEM IDENTIFICATION" (Paragraph 10).
- ▶ 5.1.6. To obtain maximum power, turn the switch (D Fig. 3) to "🔥🔥".

NOTE: IN THE EVENT OF HEATER BEING TURNED OFF DUE TO RUNNING OUT OF FUEL, TURN THE HEATER OFF, REFUEL AND TURN IT BACK ON (SEE PARA. 5.1.).

▶▶ 5.2. TURNING THE HEATER OFF:

⚠ WARNING: DO NOT CUT THE POWER OR DISCONNECT THE FEEDER CABLE BEFORE THE HEATER COOLS DOWN COMPLETELY (ab. 5 minutes).

- ▶ 5.2.1. Turn the "ON/OFF" switch "OFF" (0) (A Fig. 3).

▶▶ 5.3. ROOM THERMOSTAT CONNECTION (Optional):

Remove the plug connected to the appliance and connect the room thermostat (Optional) (C Fig. 3).

▶▶ 6. MAINTENANCE

THE FILTERS MAY NEED TO BE CLEANED DEPENDING ON THE QUALITY OF THE FUEL USED:

▶▶ 6.1. LOADING FILTER (Fig. 4):

- ▶ 6.1.1. Remove the tank's plug (A).
- ▶ 6.1.2. Remove the filter (B) from the tank.
- ▶ 6.1.3. Clean the filter (B) with clean fuel; make sure you do not damage it.
- ▶ 6.1.4. Put the filter (B) back in the tank.
- ▶ 6.1.5. Close the plug (A).

▶▶ 6.2. INTAKE FILTER (Fig. 5):

- ▶ 6.2.1. Remove the cup (A).
- ▶ 6.2.2. Take out the filter (B) from the cup. Make sure you preserve the gaskets.
- ▶ 6.2.3. Clean the filter (B) with clean fuel; make sure you do not damage it.
- ▶ 6.2.4. Put the filter (B) back into the cup.
- ▶ 6.2.5. Put the glass (A) back, make sure you reassemble the gaskets correctly.

▶▶ 6.3. TANK (Fig. 6):

- ▶ 6.3.1. Empty the fuel from the tank by removing the discharge plug at the bottom of the tank. Dispose of the fuel appropriately and in line with current standards.
- ▶ 6.3.2. If you notice any residue, pour clean fuel into the tank and rinse again.
- ▶ 6.3.3. Close the drain plug and the tank plug.

▶▶ 7. HANDLING, TRANSPORT AND STORAGE

WARNING: BEFORE HANDLING, TRANSPORT OR STORAGE, SWITCH OFF THE HEATER, WAIT FOR IT TO COOL COMPLETELY, DISCONNECT THE POWER SUPPLY PLUG FROM THE MAINS AND MAKE SURE THE PLUGS OF THE TANK ARE CLOSED TIGHTLY.

▶▶ 7.1. HANDLING:

See Fig. 7

The heater can be easily handled by the wheels and handles. To handle the heater better:

- ▶ 7.1.1. Release the handles from their closed position (pull the locking pin outwards).
- ▶ 7.1.2. Lock the handles in a handling position.
- ▶ 7.1.3. Move the heater by lifting the handles and making it slide on its wheels.
- ▶ 7.1.4. Put the handles back into their closed position.

▶▶ 7.2. TRANSPORT:

See Fig. 8

It is possible to lift and move the heater from the specific anchoring points.

▶▶ 7.3. STORAGE:

IN ORDER TO KEEP THE HEATER IN THE BEST POSSIBLE CONDITIONS, WE RECOMMEND FOLLOWING THE PROCEDURE BELOW:

- ▶ 7.3.1. Empty the fuel from the tank by removing the discharge plug at the bottom of the tank. Dispose of the fuel appropriately and in line with current standards.
- ▶ 7.3.2. If you notice any residue, pour clean fuel into the tank and rinse again.
- ▶ 7.3.3. Close the drain plug and the tank plug.
- ▶ 7.3.4. In order to keep the heater in the best conditions possible, we recommend placing it in a dry place away from potential external damage.

▶▶ 8. DISPLAY ERRORS

See B Fig. 3

ERROR	CAUSE	SOLUTION
OPERATION ERROR		
F0	1. The "ON/OFF" switch is turned "ON" (I) when the heater is plugged in	1. After disconnecting the heater, see that the switch is in the "OFF" (0) position, plug the heater in and turn the switch "ON" (I)
PHOTOCELL ERROR		
F1	1. No fuel 2. Fuel is contaminated 3. Photocell is dirty or damaged 4. Fuel filter is dirty 5. Ignition error	1. Turn the switch "OFF" (0), refill the fuel tank 2. Turn the switch "OFF" (0) empty and refill the fuel tank. Clean the filter using clean fuel, do not damage the filter (SEE PARA. 6) 3. Contact the technical service center 4. SEE PARA. 6 5. Contact the technical service center
TEMPERATURE CONTROL SENSOR ERROR		
F2	1. Interrupted cable 2. Sensor is damaged	1. Contact the technical service center 2. Contact the technical service center
THERMOSTAT ERROR		
F3	1. Internal heater overheating 2. Antitilting sensor intervent	1. Turn the heater off, wait until it is cooled down 2. Place the heater on a level and stable surface
INCORRECT VOLTAGE		
F4	1. Incorrect voltage	1. Check voltage of your electric supply system
NO SWITCH-ON AFTER THREE ATTEMPTS		
FF	1. No fuel 2. Dirty fuel filter 3. Dirty or defective photocell 4. Dirty or defective nozzle 5. Anti-tilting sensor trip	1. Contact the technical service center 2. Contact the technical service center 3. Contact the technical service center 4. Contact the technical service center 5. Contact the technical service center

►► 9. PREVENTIVE MAINTENANCE SCHEDULE

WARNING: BEFOR INITIATING ANY REPAIR OR MAINTENANCE PROCEDURE UNPLUG THE FEEDER CABLE AND MAKE SURE THAT THE HEATER IS COOLED DOWN.

COMPONENT	MAINTENANCE FREQUENCY	MAINTENANCE PROCEDURE
Fuel tank	Clean every 150-200 hours of operation or when necessary	Empty and rinse with fresh fuel
Nozzle	Clean or replace once per season or when necessary	Contact the technical service center
Photocell	Clean once per season or when necessary	Contact the technical service center
Fuel filter	Clean or replace twice per season or when necessary	Clean the fuel filter with clean fuel
Ignition device	Clean or replace every 1.000 hours of operation, or when necessary	Contact the technical service center
Fan blades	Clean when necessary	Contact the technical service center

►► 10. PROBLEM IDENTIFICATION

PROBLEM	POSSIBLE CAUSE	POSSIBLE SOLUTION
Heater doesn't run	<ol style="list-style-type: none"> 1. Heater blocked 2. The power switch is in the "OFF" (0) position 3. No power 4. Feeder cable unplugged 5. Blocked control card 6. Wrong thermostat setting 7. Temperature sensor override 8. Fuse damaged 	<ol style="list-style-type: none"> 1. Restart the heater 2. Turn the switch "ON" (I) 3A. Plug the feeder cable properly into the socket 3B. Check the power supply network 3C. Contact the technical service center 4. Contact the technical service center 5A. Restart the heater 5B. Identify the display error 5C. Contact the technical service center 6. Calibrate the thermostat by setting it higher than ambient temperature 7A. Wait at least ten minutes then try to run ignition again 7B. Contact the technical service center 8. Contact the technical service center
Motor/pump runs but the flame does not start	<ol style="list-style-type: none"> 1. No fuel 2. Ignition device is dirty 3. Fuel filter is dirty 4. Nozzle is dirty 5. Photocell is dirty, damaged or installed improperly 6. Foreign substances present in the tank 7. Electrodes are used up or placed at an improper distance 	<ol style="list-style-type: none"> 1. Turn off the heater, refill the fuel tank then restart the heater 2. Contact the technical service center 3. Clean the filter using clean fuel 4. Contact the technical service center 5. Contact the technical service center 6. Empty and refill the fuel tank with clean fuel 7. Contact the technical service center
Fan blocked or spins too slowly	<ol style="list-style-type: none"> 1. Engine damaged 	<ol style="list-style-type: none"> 1. Contact the technical service center

WIRING DIAGRAMS - SCHEMI ELETTRICI - SCHALTPLÄNE - ESQUEMAS ELÉCTRICOS - SCHEMAS ELECTRIQUES - ELEKTRISCHE SCHEMA'S - ESQUEMA ELÉTRICO - ELEKTRISKE SKEMAER - SÄHKÖKAAVIOT - KOPLINGSSKJEMA - ELEKTRISKA KOPPLINGSSCHEMAN - SCHEMATY ELEKTRYCZNE - ЭЛЕКТРИЧЕСКИЕ СХЕМЫ - ELEKTRICKÁ SCHÉMATA - VILLANYBEKÖTÉSI RAJZOK - ELEKTRİK ŞEMALARI - ELEKTRİK ŞEMASI - ELEKTRIČNE SHEME - ELEKTROS SCHEMOS - ELEKTRISKĀS SHĒMAS - ELEKTRISKEE-MID - SCHEME ELECTRICHE - ELEKTRICKÉ SCHÉMY - ЕЛЕКТРИЧЕСКИ СХЕМИ - ЕЛЕКТРОСХЕМА - ELEKTRIČNA ŠEMA - ΗΛΕΚΤΡΙΚΟ ΣΧΗΜΑ - 线路图 - ЭЛЕКТРЛІ СУЛБЕЛЕР

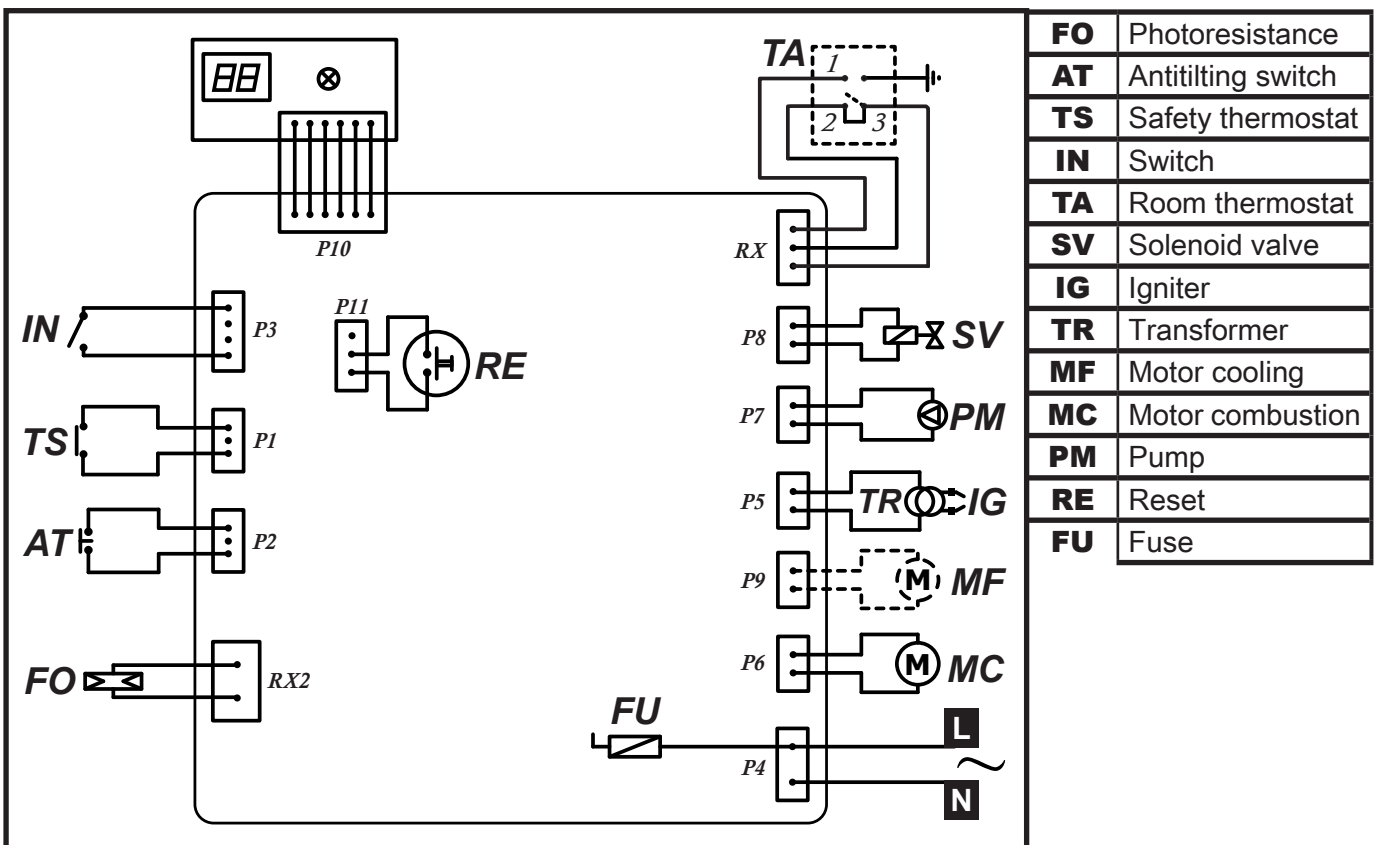



CE CONFORMITY CERTIFICATE - DICHIARAZIONE DI CONFORMITÀ CE - EG-KONFORMITÄT SERKLÄRUNG - DECLARACIÓN DE CONFORMIDAD CE - DECLARATION DE CONFORMITE CE - EG-CONFORMITEITVERKLARING - DECLARAÇÃO DE CONFORMIDADE CE - EU-OVERENSSTEMMELSESERKLÆRING - EY-VAATIMUSTENMUKAISUUSVAKUUTUS - CE-SAMSVARERKLÆRING - EG-FÖRSÄKRAN OM ÖVERENSSTÄMMELSE - DEKLARACJA ZGODNOŚCI WE - ДЕКЛАРАЦИЯ О СООТВЕТСТВИИ CE - PROHLÁŠENÍ O SHODĚ CE - EK MEGFELELŐSÉGI NYILATKOZAT - IZJAVA O SKLADNOSTI IN OZNAKA CE - CE UYGUNLUK BEYANI - IZJAVA CE O SUKLADNOSTI - ES ATITIKTIES DEKLARACIJA - EK ATBILSTĪBAS - DEKLARĀCIJA - EÜ VASTAVUSDEKLARATSIOON - DECLARAȚIE DE CONFORMITATE CE - PREHLÁSENIE O ZHODE CE - ДЕКЛАРАЦИЯ ЗА СЪВМЕСТИМОСТ CE - ДЕКЛАРАЦИЯ ВІДПОВІДНОСТІ CE - IZJAVA CE O PRIKLADNOSTI ΔΗΛΩΣΗ ΣΥΜΜΟΡΦΩΣΗΣ CE - CE 符合性声明

MCS ITALY S.p.A. Via Gardesana 11, -37010- Pastrengo (VR), ITALY

Product: - Prodotto: - Produkt: - Producto: - Produit: - Product: - Produto: - Produkt: - Tuote: - Produkt: - Produkt: - Produkt: - Изделие: - Výrobek: - Termék: - Izdelek: - Ürün: - Proizvod: - Gaminys: - Ierīce: - Toode: - Produsul: - VÝrobok: - Продукт: - Виріб: - Proizvod: - Προϊόν: - 产品:

XL 91

We declare that it is compliant with: - Si dichiara che è conforme a: - Es wird als konform mit den folgenden Normen erklärt: - Se declara que está en conformidad con: - Nous déclarons sa conformité à: - Hierbij wordt verklaard dat het product conform is met: - Declara-se que está em conformidade com: - Vi erklærer at produktet er i overensstemmelse med: - Vakuutetaan olevan yhdenmukainen: - Man erklærer at apparatet er i overensstemmelse med: - Härmed intygas det att produkten är förenlig med följande: - Oświadczam, że jest zgodny z: - Заявляем о соответствии требованиям: - Prohlašuje se, že je v souladu s: - Kijelentjük, hogy a termék megfelel az alábbiaknak: - Izpolnjuje zahteve: - Aşağıdaki standartlara uygun olduğunu beyan ederiz: - Izjavljuje se da je u skladu s: - Pareiškiame, kad atitinka: - Tiek deklarēts, ka atbilst: - Käesolevaga deklareeritakse, et toode vastab: - Declarăm că este conform următoarelor: - Prehlasuje sa, že je v súlade s: - Декларира се че отговаря на: - Відповідає вимогам: - Izjavljuje se da je u skladu s: - Δηλώνουμε ότι είναι σύμφωνο με: - 兹证明符合:

2014/30/EU, 2014/35/EU, 2009/125/EC

EN 62233:2008, EN 61000-3-2:2014, EN 61000-3-3:2013, EN 55014-1:2006/A2:2011, EN 55014-2:2015, EN 60335-1:2012/A11:2014, EN 60335-2-102:2016, (EU) N°. 327/2011

Pastrengo, 14/04/2017

Stefano Verani (CEO MCS Group)

► en - DISPOSAL OF THE PRODUCT

- This product has been designed and manufactured with top-quality materials and components, which can be re-cycled and re-used.
- When a crossed-wheely bin symbol is attached to the product, it means that the product is protected by the, 2012/19/UE European Directive.
- Please obtain information regarding the local differentiated collection system for electrical and electronic products.
- Respect local Standards in force and do not dispose of old products as normal domestic waste. Correct disposal of the product helps to prevent possible negative consequences for health, the environment and mankind.

► it - SMALTIMENTO DEL PRODOTTO

- Questo prodotto è stato progettato e fabbricato con materiali e componenti di alta qualità, che possono essere riciclati e riutilizzati.
- Quando ad un prodotto è attaccato il simbolo del bidone con le ruote segnato da una croce, significa che il prodotto è tutelato dalla Direttiva Europea 2012/19/UE.
- Si prega di informarsi in merito al sistema locale di raccolta differenziata per i prodotti elettrici ed elettronici.
- Rispettare le norme locali in vigore e non smaltire i prodotti vecchi nei normali rifiuti domestici. Il corretto smaltimento del prodotto aiuta ad evitare possibili conseguenze negative per la salute dell'ambiente e dell'uomo.

► de - ENTSORGUNG DES PRODUKTS

- Dieses Produkt wurde unter Verwendung von Qualitätsmaterialien und -bauteilen entwickelt und hergestellt, die recycelt und wieder verwendet werden können.
- Ist ein Produkt gekennzeichnet durch die Mülltonne mit Rädern und einem Kreuz, wird hier angezeigt, dass dieses Produkt durch die europäische Richtlinie 2012/19/UE überwacht ist.
- Es wird gebeten, sich über die vor Ort bestehende Mülltrennung bezüglich elektrischer und elektronischer Produkte zu informieren.
- Die vor Ort geltenden Vorschriften zur Müllentsorgung müssen eingehalten werden und alte Produkte dürfen nicht zusammen mit dem Hausmüll entsorgt werden. Die ordnungsgemäße Entsorgung des Produkts hilft mögliche negative Folgen für Gesundheit und Umwelt zu vermeiden.

► es - ELIMINACIÓN DEL PRODUCTO

- Este producto ha sido diseñado y fabricado con materiales y componentes de alta calidad que se pueden reciclar y reutilizar.
- Cuando en el producto se encuentra el símbolo del contenedor con las ruedas tachado con una cruz, significa que el producto está tutelado por la Directiva europea 2012/19/UE.
- Se ruega informarse acerca del sistema local de recogida selectiva para los productos eléctricos y electrónicos.
- Respete las normas locales vigentes y no elimine los productos viejos junto con los residuos domésticos normales. La eliminación correcta del producto ayuda a evitar posibles consecuencias negativas para la salud del ambiente y del hombre.

► fr - SE DÉBARRASSER DE VOTRE PRODUIT USAGÉ

- Ce produit a été conçu et fabriqué avec des matériaux et des composants de haute qualité, qui peuvent être recyclés et utilisés de nouveau.
- Lorsque le symbole d'une poubelle à roue barrée est appliqué à un produit, cela signifie que le produit est couvert par la Directive Européenne 2012/19/UE.
- Veuillez vous informer du système local de séparation des déchets électriques et électroniques.
- Veuillez agir selon les règles locale set ne pas jeter vos produits usagés avec les déchets domestiques usuels. Jeter correctement votre produit usagé aidera à prévenir les conséquences négatives potentielles contre l'environnement et la santé humaine.

► nl - VERWIJDERING VAN HET PRODUCT

- Dit product werd ontworpen en gemaakt met hoogwaardige materialen en componenten, die gerecycleerd en herbruikt kunnen worden.
- Wanneer op een product het symbool van de afvalbak op wielen met een kruis erdoor is aangebracht, betekent dit dat het product valt onder de Europese Richtlijn 2012/19/UE.
- Gelieve inlichtingen in te winnen betreffende het plaatselijke systeem voor gedifferentieerde inzameling van elektrische en elektronische toestellen.
- Respecteer de plaatselijke normen die van kracht zijn, en verwijder de oude toestellen niet als gewoon huishoudelijk afval. Een correcte verwijdering van het product helpt om mogelijke negatieve gevolgen voor de gezondheid van mens en milieu te voorkomen.

► pt - ELIMINAÇÃO DO PRODUTO

- Este produto foi projetado e fabricado com materiais e componentes de alta qualidade que podem ser reciclados e reutilizados.
- Quando for afixado em um produto o símbolo do bidão com rodas marcado com uma cruz, significa que o produto é protegido pela Diretiva Europeia 2012/19/UE.
- Solicitamos informar-se sobre o sistema local de recolha diferenciada para os produtos elétricos e eletrônicos.
- Respeitar as normas locais em vigor e não eliminar os produtos antigos como normais detritos domésticos. A correta eliminação do produto ajuda a evitar possíveis consequências negativas para a saúde do ambiente e do homem.